

GR



UNIDIRECTIONAL ROUND GUILLOTINE DAMPER

DESCRIPTION

- Gas valve, with round damper design.
- Unidirectional guillotine damper.
- Various seat and packing materials available.
- Face-to-face distance in accordance with **CMO valves** standard.

GENERAL APPLICATIONS

This guillotine damper valve is suitable to work with a large range of airs and gases. It is particularly suitable as an isolation element in order to allow inspections, maintenance and repairs in the ducts. Used mainly in:

- Cement factories.
- Steel mills.
- Electrical power stations.
- Chemical plants.
- Energy sector.

SIZES

From DN 150 up to DN 3000 (larger sizes on request). Check with **CMO valves** for the general dimensions of a specific damper.

WORK (ΔP):

Maximum standard work pressure is 0.5 kg/cm²; greater pressures upon request.

FLANGES

The connections of flanges and between faces are in accordance with **CMO valves** standard, although we can also adapt to the customer's needs.

SEALTIGHTNESS

The standard seal tightness percentage of CMO varies between 98.5% and 99.5%. 100% seal-tightness is also possible (upon request) using dual gate systems and injections of air with a fan.



fig. 1

APPLICATION OF EUROPEAN DIRECTIVES

See document of European Directives applicable to **CMO Valves**.

** For further information on categories and zones please contact the **CMO VALVES**. Technical-Commercial Dept.*

QUALITY DOSSIER

The seal-tightness of the seat area is measured with gauges. Material and testing certificates can be supplied on request.

ADVANTAGES

The main elements of this damper are the body, which contains a gate or board inside which moves longitudinally, and has a peripheral sealing system to prevent leakages of gas, regardless of the movement stage of the gate or board. They are also fitted with the necessary supports and actuators. The main characteristics of the **GR** guillotine damper are:

- Good isolation between areas and from the outside.
- Minimum loss of load when the damper is in open position.
- Little space required throughout the duct.
- Good resistance to high temperatures and deterioration.

The stem protection hood is independent from the handwheel securing nut, this means the hood can be disassembled without the need to release the handwheel. This advantage allows regular maintenance operations to be performed, such as lubricating the stem, etc.

The **CMO** damper stem is made from stainless steel 18/8. This is another additional benefit, since some manufacturers supply it with 13% chrome, which quickly rusts.

The operating wheel is manufactured in nodular cast GGG-50. Some manufacturers supply it in common cast-iron, which can lead to breakage in the event of very high operation torque or a bang.

The yoke is has a compact design with the bronze actuator nut protected in a sealed and lubricated box. This makes it possible to move the valve with a key, even without the handwheel (in other manufacturers' products this is not possible).

The pneumatic actuator's upper and lower covers are made of GGG-40 nodular cast iron, making them highly shock resistant. This characteristic is essential in pneumatic actuators.

The pneumatic cylinder's seals are commercial products and can be purchased worldwide. This means it is not necessary to contact **CMO valves** every time a seal is required.

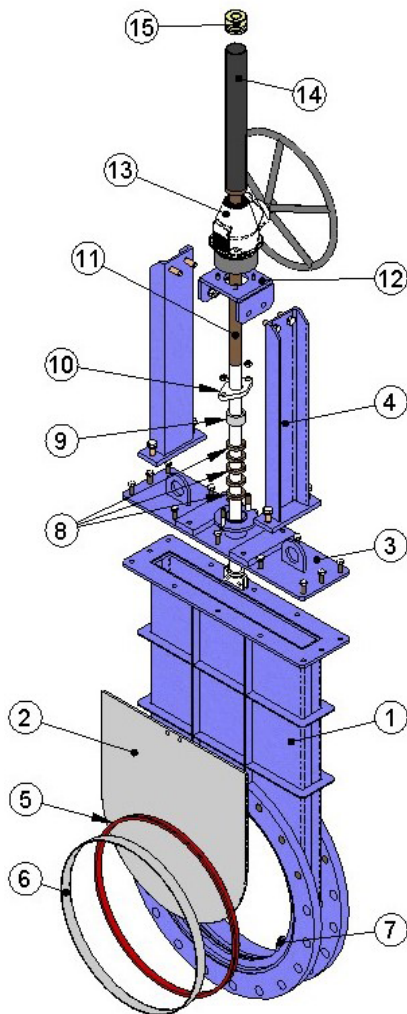

Fig. 2

STANDARD COMPONENTS LIST

COMPONENT	VERSION H ⁹ F ⁹	VERSION INOX
1 Body	S275JR	AISI316
2 Gate	AISI304	AISI316
3 Cover	S275JR	AISI316
4 Support plates	S275JR	AISI316
5 Seal	EPDM	EPDM
6 Seal ring	AISI304	AISI316
7 Wedges	AISI304	AISI316
8 Packing	SYNT+PTFE	SYNT+PTFE
9 Gland bushing	AISI304	AISI316
10 Gland flange	S275JR	AISI316
11 Stem	AISI303	AISI316
12 Actuator support	S275JR	AISI316
13 Geared motor	---	---
14 Hood	ST-37	ST-37
15 Cap	PLASTICO	PLASTICO

Table. 1

DESIGN CHARACTERISTICS

BODY

The body of this type of damper is usually mechanically welded and made from different thicknesses with reinforcements and structural profiles in order to prevent any deformation. The material normally used is S275JR carbon steel, although, in accordance with the work pressure and temperature there are other special materials to choose, such as steel H11, 16Mo3, stainless steel. (AISI304, AISI316, AISI310),.... As standard, carbon steel dampers are painted with an anti-corrosive protection of 80 microns of EPOXY, colour RAL 5015. Nevertheless, other types of anti-corrosion protections are available.

The body has an approximate height of twice that of the duct, in order to loosen the gate inside when it is in open position. The upper section includes a screwed-down cover which seals the upper part of the body in order to achieve a completely hermetic interior chamber, to which end a cardboard seal is positioned between the cover and the body. Welded onto the cover is housing for the seal, comprising multiple packing lines. Seal tightness between the cover and the stem is achieved by pressing this packing using a flange and bushing. The choice of packing material depends mainly on the work temperature.

The connection between the duct and the valve is usually made by screwing down the flanges on the body, although the connection can also be made by welding. In the latter case, great care must be taken when welding, as this may produce deformations in the damper due to the tensions created by the welding, possibly leading to operation problems.

The body provides a full, continuous flow, meaning the loss of load in open position is minimum, in order to provide large flows with small losses of load. Wedges are welded onto the inside of the body, coinciding with the gate wedges when the damper is in closed position. The purpose of these wedges is to push the gate against the seal in order to achieve greater seal tightness.

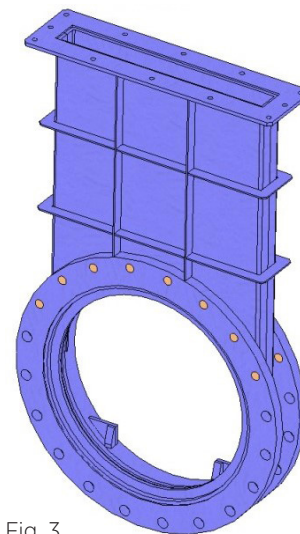

Fig. 3

GATE

The standard manufacturing materials are AISI304 stainless steel in dampers with carbon steel body and AISI316 stainless steel in dampers with AISI316 body. They can also be supplied on request with other materials or combinations.

In accordance with the dimensions of the damper, reinforcements are commonly welded to the gate (as shown in fig. 4) in order to achieve the necessary rigidity. When the work temperature is very high, there is also the possibility of mounting a board filled with refractory material for better isolation, rather than mounting a single gate. The stem is connected to the upper part of the gate, with its longitudinal movement making the damper open or close. When the gate comes down and moves to close position, the seat wedges are supported on the body wedges, pushing the gate against the seal to achieve greater seal tightness.

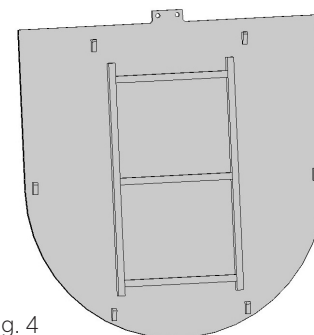

Fig. 4

SEAT

Different types of seats are available according to the working application:

- **Seat 1: Metal / metal seat.** This type of seat does not include any kind of resilient seat and the estimated leakage is 1.5% of the pipe flow. The sealing frame is welded to the body and is made of the same material; with this type of seal we estimate seal tightness of 98.5%. As with the gate, there are wedges in the body in order to adjust and increase the contact of the gate with the sealing frame..
- **Seat 2:** Standard soft-seated valve. This type of seat includes a resilient seat which is fixed to the inside of the body via a stainless steel retaining flange.

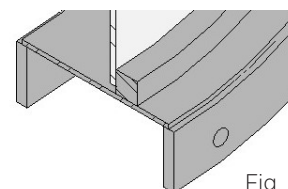
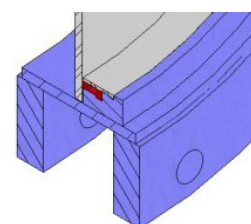

Fig. 5



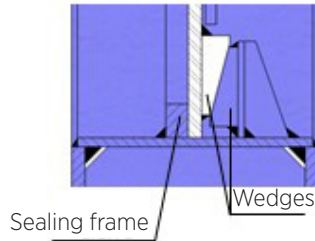

Fig. 6

Depending on the work temperature and the sealtightness to be achieved, bronze seals, graphite, etc. can also be used.

RESILIENT SEAT MATERIALS

EPDM

Recommended for temperatures no higher than 90°C*, providing the damper with 100% watertight integrity. Application: Water and acids.

NITRILE

It is used in fluids containing fats or oils at temperatures no higher than 90°C*. It provides the damper with 100% watertight integrity.

VITON

Suitable for corrosive applications and continuous high temperatures of up to 190°C and peaks of 210°C. It provides the damper with 100% watertight integrity.

SILICONE

Mainly used in the food industry and for pharmaceutical products with temperatures no higher than 200°C. It provides the damper with 100% watertight integrity.

PTFE

Suitable for corrosive applications and pH between 2 and 12. Does not provide the damper with 100% watertight integrity. Estimated leakage: 0.5 % of the tube flow.

Note: In some applications other types of resilient materials are used, such as hypalon, butile or natural rubber. Please contact us if you require one of these materials.

PACKING

Standard **CMO valves** packing comprises several lines of SYNT.+PTFE packing which provide sealtightness between the stem and the cover, avoiding any type of leakage into the atmosphere. It is located in an easily accessible place and can be replaced without dismantling the damper from the pipeline. Below we indicate various types of packing available according to the application where the damper is found:

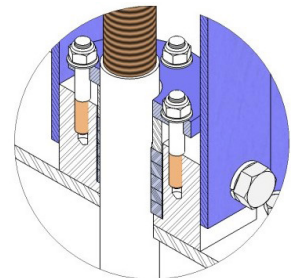

Fig. 7

GREASED COTTON (Recommended for hydraulic services)

This packing is composed of braided cotton fibres soaked in grease both inside and out. It is for general use in hydraulic applications in both pumps and valves.

DRY COTTON

This packing is composed of cotton fibres. It is for general use in hydraulic applications with solids.

COTTON + PTFE

This packing is composed of braided cotton fibres soaked in PTFE both inside and out. It is for general use in hydraulic applications in both pumps and valves.

SYNTHETIC + PTFE

This packing is composed of braided synthetic fibres soaked in PTFE both inside and out. It is for general use in hydraulic applications in both pumps and valves and in all types of fluids, especially corrosive ones, including concentrated and oxidising oils. It is also used in liquids with solid particles in suspension.

GRAPHITE

This packing is composed of high-purity graphite fibres. A diagonal braiding system is used and it is impregnated with graphite and lubricant which helps to reduce porosity and improve operation.

It has a wide range of applications as graphite is resistant to steam, water, oils, solvents, alkali and most acids.

CERAMIC FIBRE

This packing is composed of ceramic material fibres. It is used mainly with air or gases at high temperatures and low pressures. They are located in an easily accessible place and can be replaced without dismantling the valve from the pipeline.

Table. 2

STEM

The **CMO** damper stem is made from stainless steel 18/8. This characteristic makes it highly resistant and provides excellent properties against corrosion. The valve design can be rising stem or non-rising stem. When a rising stem is required for the damper, a stem hood is supplied to protect the stem from contact with dust and dirt, besides keeping it lubricated.

PACKING GLAND

The combination of the gland flange plus gland socket allows uniform pressure and force to be applied in the packing, in order to ensure seal tightness (see fig. 7 of the previous sheet).

As standard, the gland bushing is usually stainless steel and the gland flange is usually the same material as the body and cover of the damper.

ACTUATORS

The damper drive system includes an actuator located in the upper section, which is attached to the cover by way of support plates. These support plates have an adaptation flange in the upper section, which the actuator is fastened to and which in turn delimit the longitudinal movement of the gate. When starting up the actuator, it exercises the torque or draw necessary in the stem or rod, which in turn is transmitted to the gate to start movement.

Our dampers are supplied with several types of actuator, bringing the advantage that, thanks to the design of **CMO valves**, they can be interchanged.

This design allows the customer to change the actuators themselves and no extra assembly accessories are required.

The total dimensions of the damper may vary in accordance with the type of actuator chosen.

MANUAL

- Handwheel with rising stem
- Handwheel with non-rising stem
- Chainwheel
- Geared motor
- Other (square nut).

AUTOMATIC

- Electric actuator
- Pneumatic cylinder.
- Hydraulic cylinder

Fig. 8

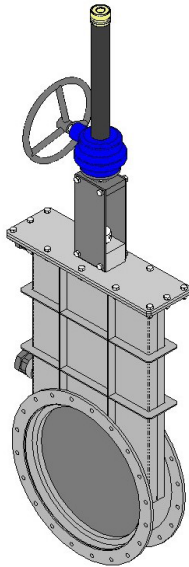

HANDWHEEL + GEAR BOX
WITH RISING STEM

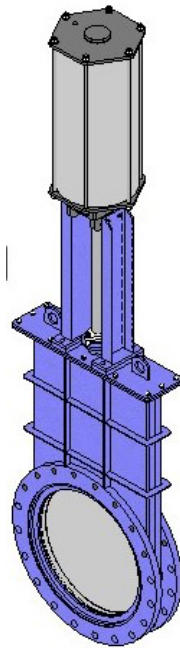

PNEUMATIC CYLINDER

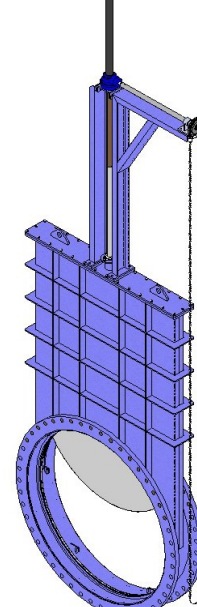

CHAIN-HANDWHEEL
WITH GEARS AND
RISING STEM

Fig. 9

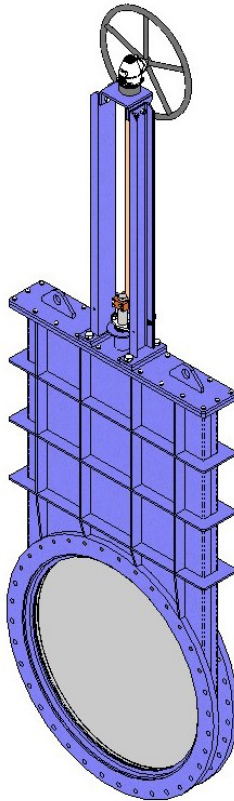

HANDWHEEL + GEAR BOX
WITH NON-RISING STEM

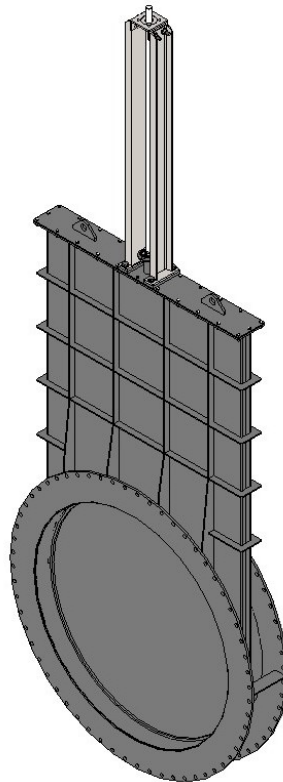

NO ACTUATOR

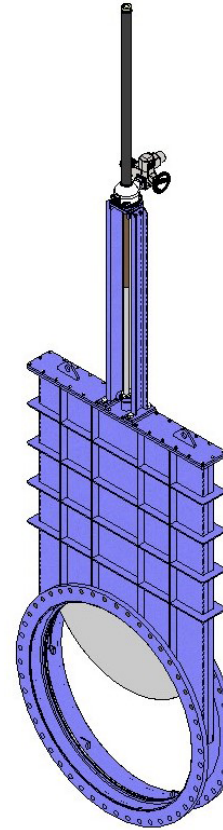

GEARED MOTOR
WITH RISING STEM

Stem extensions have also been developed, allowing the actuator to be located far away from the damper, to suit all needs. Please consult our technicians beforehand.

Wide range of accesories available

- Mechanical stops
- Locking devices
- Emergency manual actuators
- Electrovalves
- Positioners
- Limit switches
- Proximity switches
- Straight floor stands (fig. 11)
- Leaning floor stand (fig. 10)
- ...

Fig. 11

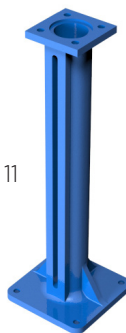

Fig. 10



ACCESORIES AND OPTIONS

Different accessories are available to adapt the damper to specific working conditions such as:

MIRROR POLISHED GATE

The mirror polished gate is especially recommended in the food industry and, as standard, in applications in which solids can stick to the gate. It is an alternative to ensure the solids slide off and do not stick to the gate.

PTFE LINED GATE

As with the mirror polished gate, it improves the damper's resistance to products that can stick to the gate.

STELLITED GATE

Stellite is added to the gate's internal perimeter to protect it from abrasion.

SCRAPER IN THE PACKING

Su función es limpiar la tajadera durante el movimiento de apertura y evitar posibles daños en la empaquetadura.

AIR INJECTION IN THE PACKING GLAND

By injecting air in the packing, an air chamber is created which improves the seal-tightness.

HEATING JACKET

Recommended in applications in which the fluid can harden and solidify inside the valve's body. An external jacket keeps the body temperature constant, preventing the fluid from solidifying.

FLUSHING HOLES IN BODY

Several holes are drilled in the body to flush air, steam or other fluids out with the aim of cleaning the valve seat before sealing.

MECHANICAL LIMIT SWITCHES, INDUCTIVE SWITCHES AND POSITIONERS

Limit switches or inductive switches are installed to indicate precise valve position, as well as positioners to indicate continuous position.

ELECTROVALVES

For air distribution to pneumatic actuators.

CONNECTION BOXES, WIRING AND PNEUMATIC PIPING

Units supplied fully assembled with all the necessary accessories.

STROKE LIMITING MECHANICAL STOPS

They allow the stroke to be mechanically adjusted, limiting the damper run.

MECHANICAL LOCKING DEVICE

Allows the valve to be mechanically locked in a set position for long periods.

EMERGENCY MANUAL ACTUATOR (HAND WHEEL /GEAR BOX)

Allows manual operation of the damper in the event of power or air failure.

INTERCHANGEABLE ACTUATORS

All actuators are easily interchangeable.

EPOXY COATING

All carbon steel bodies and components of **CMO** dampers are EPOXY coated, giving the dampers great resistance to corrosion and an excellent surface finish. **CMO**'s standard colour is blue RAL-5015.

BONNET

The body of this damper has a bonnet, which brings numerous benefits in terms of seal tightness and protection.

TYPES OF EXTENSION

When the damper needs to be operated from a distance, the following different types of actuators can be fitted:

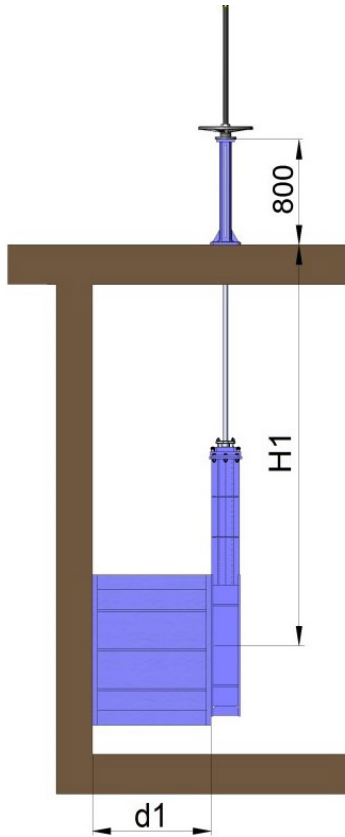

fig. 12

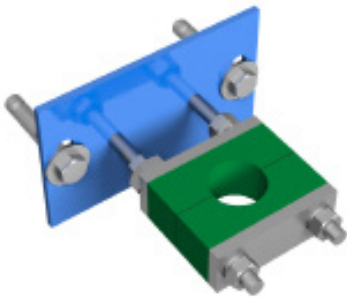

fig. 13

EXTENSION: FLOOR STAND

This extension is performed by coupling a rod to the stem. By defining the length of the rod, the desired extension is achieved. A floor stand is normally installed to support the actuator.

The definition variables are as follows:

H1: Distance from the damper shaft to the base of the stand

d1: Separation from the wall to the end of the connecting flange

CHARACTERISTICS

- It can be coupled to any type of actuator.
- A stem support-guide is recommended (fig. 13) every 1.5 m.
- The standard floor stand is 800 mm high (fig. 12). Other floor stand measurements available on request.
- A position indicator can be fitted to determine the damper's percentage of opening.
- Possibility of leaning floor stand (fig. 14).



fig. 14

COMPONENTS LIST

COMPONENT	STANDARD VERSION
Stem	AISI 304
Stem	AISI 304
Support-Guide	Carbon steel with EPOXI coating
Slide	Nylon
Floor stand	GJS-500 with EPOXI coating

Table. 3

EXTENSION (FIG. 15)

Consists of raising the actuator. The pipe will rotate with the wheel or key when the damper is operated, although this will always remain at the same height.

The definition variables are as follows:

H1: Distance from the damper shaft to the desired height of the actuator.

d1: Separation from the wall to the end of the connecting flange.

CHARACTERISTICS:

- Standard actuators: Handwheel and "Square Nut".
- A pipe support-guide is recommended every 1.5m.
- The standard materials are: EPOXY coated carbon steel or stainless steel.

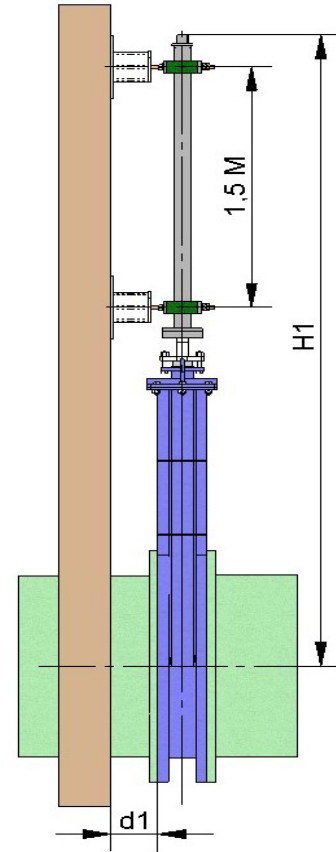

Fig. 15

EXTENSION: EXTENDED SUPPORT PLATES (FIG. 16)

When a short extension is required, it can be achieved by extending the support plates. An intermediate yoke can be fitted to reinforce the support plates' structure.

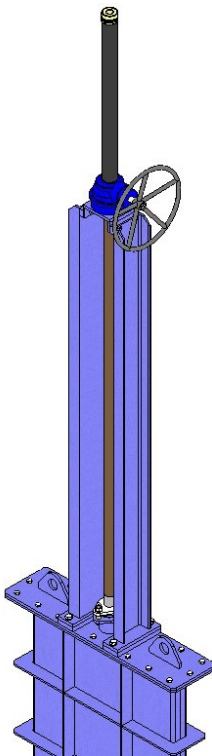

fig. 16

EXTENSION: UNIVERSAL JOINT (FIG. 17)

If the damper and the actuator are not in correct alignment, the problem can be resolved by fitting a universal joint.

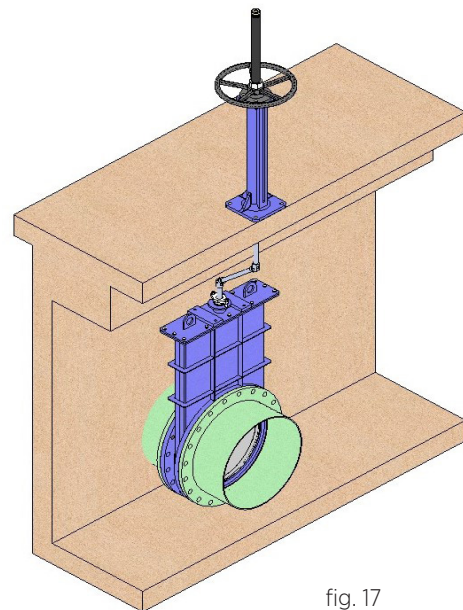

fig. 17

DIMENSIONS FOR DIFFERENT OPTIONS

As mentioned above, the general dimensions and gaps are defined in accordance with **CMO valves** standard. However, since these valves depend on multiple variables, such as work pressure, temperature, dimensions, etc, If you would like to know the general dimensions of a particular damper, please contact **CMO valves** to request this information.



www.cmovalves.com



CMO VALVES

QMS CERTIFIED BY LRQA
Approval number ISO9001 0035593

**CMO HEADQUARTERS
MAIN OFFICES & FACTORY**

Amategi Aldea, 142
20400 Tolosa
Guipuzcoa (Spain)

Tel.: (+34) 943 67 33 99
Fax: (+34) 943 67 24 40

cmo@cmovalves.com
www.cmovalves.com

CMO MADRID

C/ Rumania, 5 - D5 (P.E. Inbisa)
28802 Alcalá de Henares
Madrid (Spain)

Tel.: (+34) 91 877 11 80
Fax: (+34) 91 879 79 94

cmomadrid@cmovalves.com
www.cmovalves.com
