

INSTRUCTIONS AND MAINTENANCE MANUAL

SERIES: ME

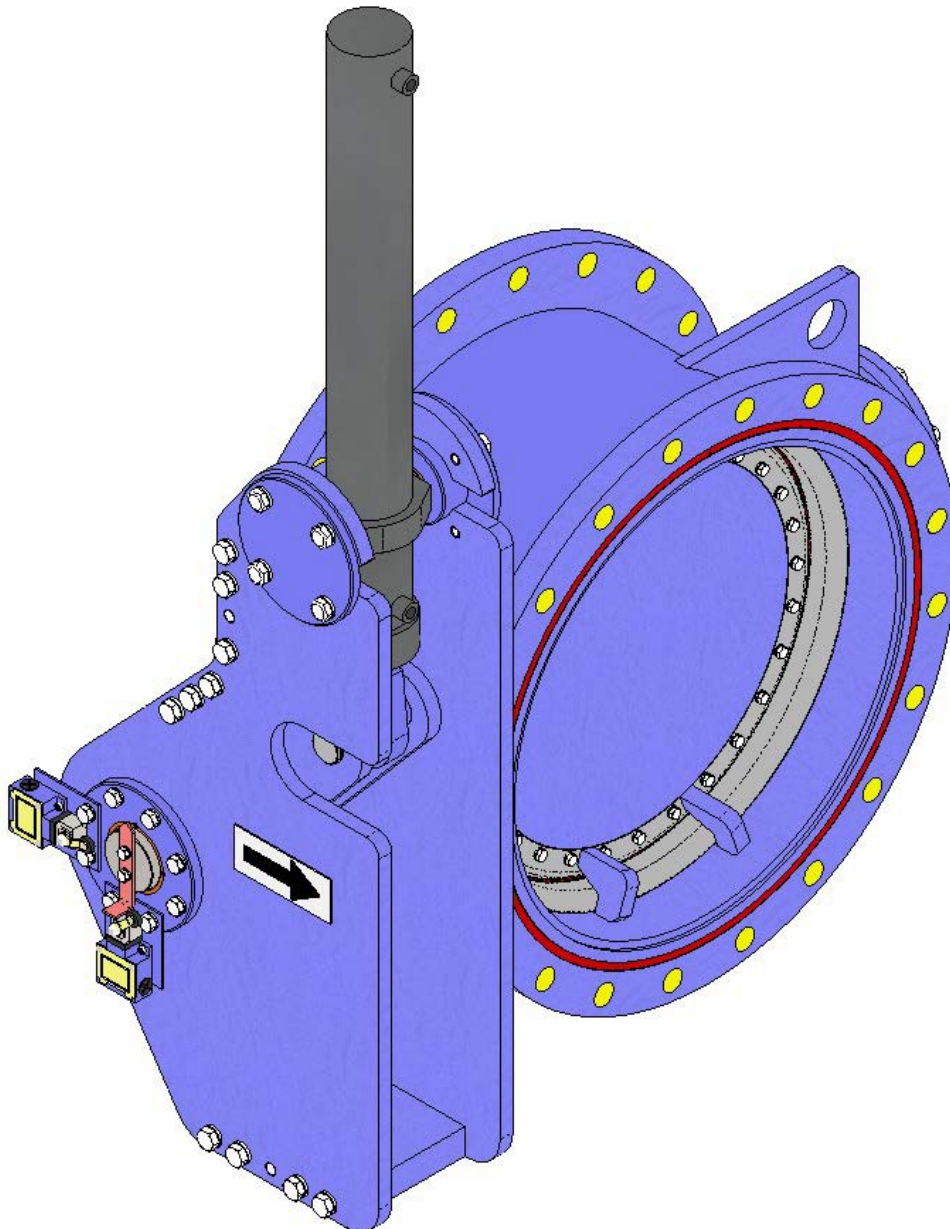

BUTTERFLY VALVE

ME SERIES

ASSEMBLY

APPLICATION OF EUROPEAN DIRECTIVES

See document of European Directives applicable to **CMO Valves**.

HANDLING

When handling the equipment please pay special attention to the following points:

- **SAFETY WARNING:** Before handling the valve, check that the crane to be used is capable of bearing its weight.
- To prevent damage, especially to the anticorrosive protection, we recommend using soft straps to lift CMO's **ME** butterfly valves. These belts must be secured in the holes fitted for this purpose in the body reinforcements.
- Do not lift the valve or hold it using the actuator. Lifting the valve by the actuator can lead to operating problems as it is not designed to withstand the valve's weight.
- Do not lift the valve by holding it in the flow passage area. The valve's machined seal ring is located in this area. If the valve is secured and lifted in this area, the seal ring surface may become damaged, leading to leakage problems whilst the valve is operating.
- Packing in wooden boxes: if the equipment is packed in wooden boxes, these must be provided with clearly marked holding areas where the slings will be placed when securing them. In the event of two or more valves being packed together, separation and securing elements must be provided between them to prevent possible movements, knocks and friction during transport. When storing two or more valves in the same box you must ensure they are correctly supported in order to prevent deformations. In the case of dispatches by sea we recommend the use of vacuum bags inside the boxes to protect the equipment from contact with sea water.
- Pay special attention to maintaining the correct levelling of the valves during loading and unloading as well as during transport in order to prevent deformations in the equipment. For this purpose we recommend the use of mounts or trestles.



INSTALLATION

In order to avoid personal harm and other types of damage (to the facilities, the valve, etc.) please follow these instructions:

- The staff responsible for the installation or operation of the equipment must be qualified and trained.
- Use suitable Personal Protective Equipment (PPE) (gloves, safety boots, goggles...).
- Shut off all lines that affect the valve and put up a warning sign to inform about the work being performed.
- Completely isolate the valve from the whole process. Depressurise the process.
- Drain all the line fluid through the valve.
- Use manual rather than electric tools during installation and maintenance, in accordance with **EN13463-1(15)**.



Before installation, inspect the valve to ensure no damage has occurred during transport or storage. Make sure that the inside of the valve body and, in particular, the seal area are clean. Inspect the installation's pipes and the flanges to make sure they are clean.

BUTTERFLY VALVE

ME SERIES

ASPECTS TO BE CONSIDERED DURING ASSEMBLY

The ME valve is unidirectional and has an arrow marked on the body indicating the flow direction. It should be remembered that the pressure and the fluid direction do not always coincide (fig. 1).

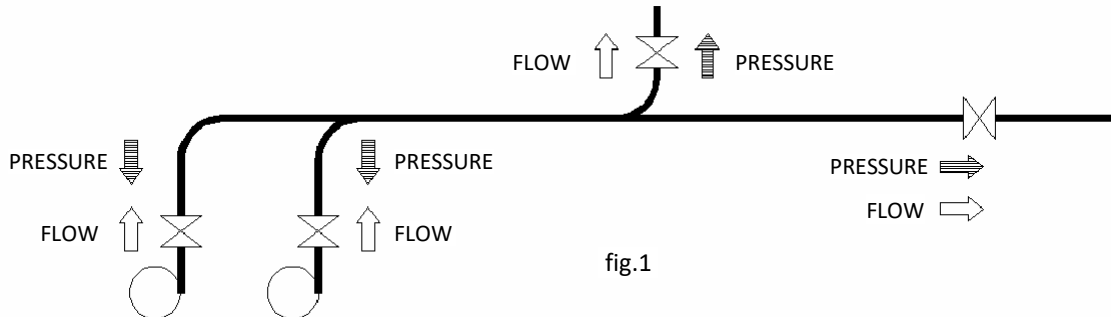

- Special care must be taken to respect the correct distance between the flanges and ensure they are correctly aligned and parallel (fig. 2). The incorrect position or installation of the flanges can cause deformations on the valve's body and this could lead to operating problems.

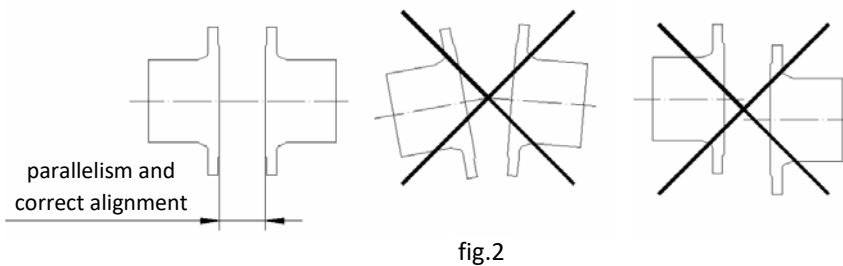

It is very important to make sure that the valve is correctly aligned and parallel to the flanges to prevent leakages and avoid deformations. Try to assemble the valve in shut-off position.

- The flange bores are usually flat through-holes, meaning the screws go beyond the flange and are screwed with washers and nuts. Although there are many different standards, the flange drilling standard is defined by the customer in accordance with needs, with the butterfly flange usually being drilled in accordance with Standard EN 1092-2 PN10. The following chart (table 1) shows the metric of the screw and the maximum torque to be applied with this drilling standard.

DN	200	250	300	350	400	500	600	700	800	900	1000	1200	1400	1600	1800	2000	2200	2400	2600	2800	3000	
Metric	M20	M20	M20	M20	M24	M24	M27	M27	M30	M30	M33	M36	M39	M45	M45	M45	M52	M52	M52	M52	M52	M56
TORQUE (Nm)	45	45	45	45	45	88	88	88	88	88	152	152	152	223	223	223	303	303	412	412	412	529

 NOTE: These values are for the flange drilling standard we consider most common, namely EN 1092-2 PN10.

table 1

- The equipment must be firmly installed in the duct. It will be joined to the duct with a screwjoint.
- The screws and nuts to be fitted must also be suitable for the operating conditions and their measurements must be in accordance with the approved plans. The screws and nuts must be tightened diametrically.

BUTTERFLY VALVE

ME SERIES

The torque to apply to the fastening screws and nuts must be correct according to the applicable standard; we recommend the initial assembly should be carried out with a low tightening torque and, after all the screws are in place, the final torque applied.

- As regards scaffolding, ladders and other auxiliary elements to be used during assembly, follow the safety recommendations indicated in this dossier.
- Once the equipment has been assembled, make sure that there are no elements, whether interior or exterior, which can interfere with the movement of clapper.
- Make the relevant connections (electric, hydraulic, etc) in the equipment's actuator system following the instructions and wiring diagrams supplied with it.
- The operation of the equipment must be coordinated with the site's control and safety staff and no modifications are permitted in the equipment's external indication elements (limit switches, positioners, etc.).
- When operating the equipment follow the safety recommendations indicated in this dossier.

ASSEMBLY POSITIONS

CMO's **ME** butterfly valves are designed for assembly with the rotation shaft mounted in horizontal position. The self-lubricated bushing fitted to facilitate the turning of the shafts is radial, and the distribution of weights for the correct operation of the valve requires the shaft to be in horizontal position. The valve is designed to work both in horizontal (fig. 3) and vertical (fig. 4) piping, provided the horizontal position of the shaft turn and the fluid direction are respected.

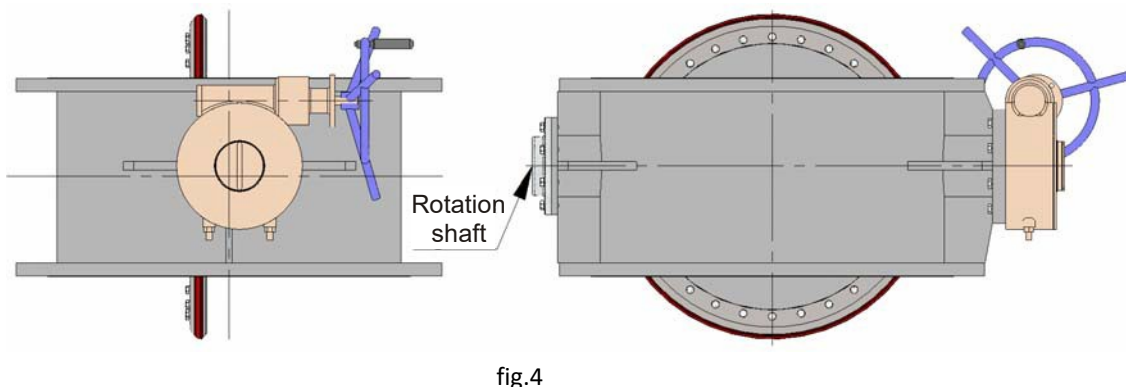
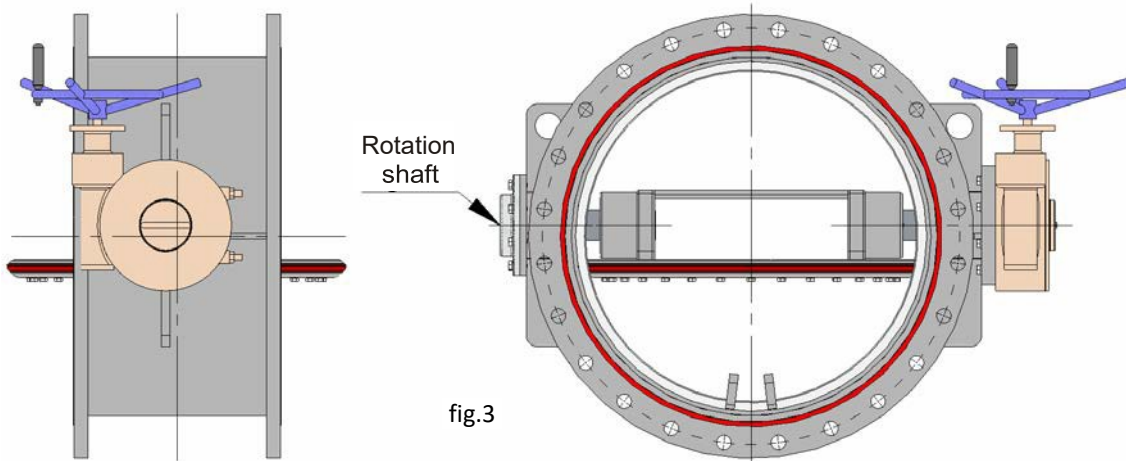

BUTTERFLY VALVE

ME SERIES

Check with CMO before installing the ME butterfly valve in another position, since the valve design can be modified on request in line with each specific case.

Once the valve has been installed, check that all the screws and nuts have been correctly tightened and that the whole valve actuator system has been correctly adjusted (electric connections, hydraulic connections, instruments, etc). If the valve has electric accessories, earth connections must be made before operating it.

All CMO valves are tested on site.

ACTUATOR

MANUAL GEARED MOTOR (fig. 5)

If the valve is to be operated, turn the handwheel clockwise to shut, or anticlockwise to open. The geared motor has an indicator in the cover to reflect the degree of opening of the valve at all times.

CHAINWHEEL

There is the option of coupling a chainwheel to the geared motor. To operate the valve pull on one of the chain's vertical drops, taking into account that sealing is carried out when the chainwheel turns clockwise.

HYDRAULIC (double and single acting)

CMO hydraulic actuators are designed to work at a standard pressure of 135 kg/cm².

This type of actuator does not require any adjustment, due to the fact that the hydraulic cylinder is designed for the exact stroke required by the valve.

In the event of double-acting hydraulic actuator (fig. 8), the hydraulic cylinder is used to open and shut the valve.

In the event of single-acting hydraulic actuator (fig. 6), the actuator comprises a hydraulic cylinder and a counterweight. The hydraulic cylinder will carry out the opening or closing operation, whilst the other operation will be carried out using the counterweight. This type of actuator is very suited to emergency situations, since the counterweight can operate even when the electrical supply fails.

MOTORISED (fig. 7)

The motorised actuator comprises an electric multi-turn actuator (motor) coupled to a geared motor.

The motor has an emergency manual actuator, which, in the event of power failure, can declutch the motor to operate the valve using the wheel.

This actuator is fitted with two limit switches which delimit the sphere of influence of the actuator, and a torque limiter in both turning directions, in order to achieve a perfect seal and protect the actuator from excess strain.

If the valve incorporates a motorised actuator, it will be accompanied with the electric actuator supplier's instructions.

BUTTERFLY VALVE

ME SERIES

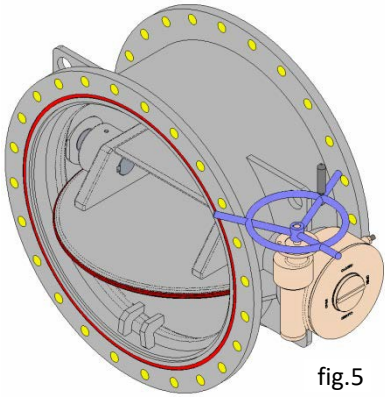

fig.5
Manual Geared
Actuator

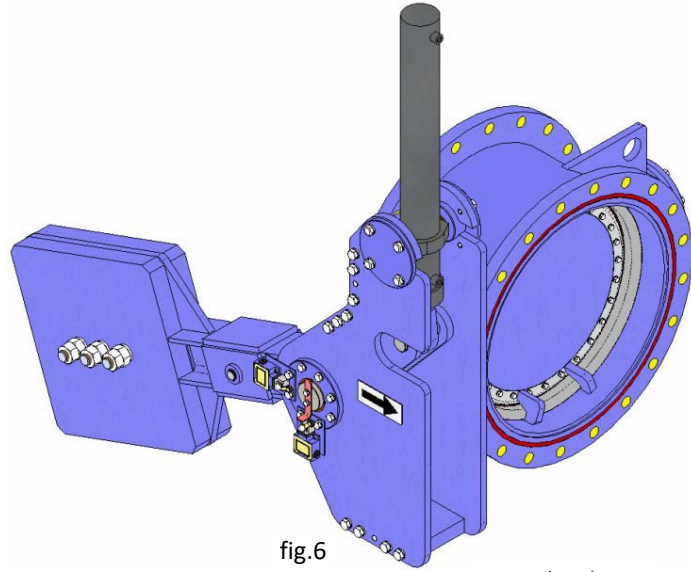

fig.6
Hydraulic
Actuator +
Counterweight

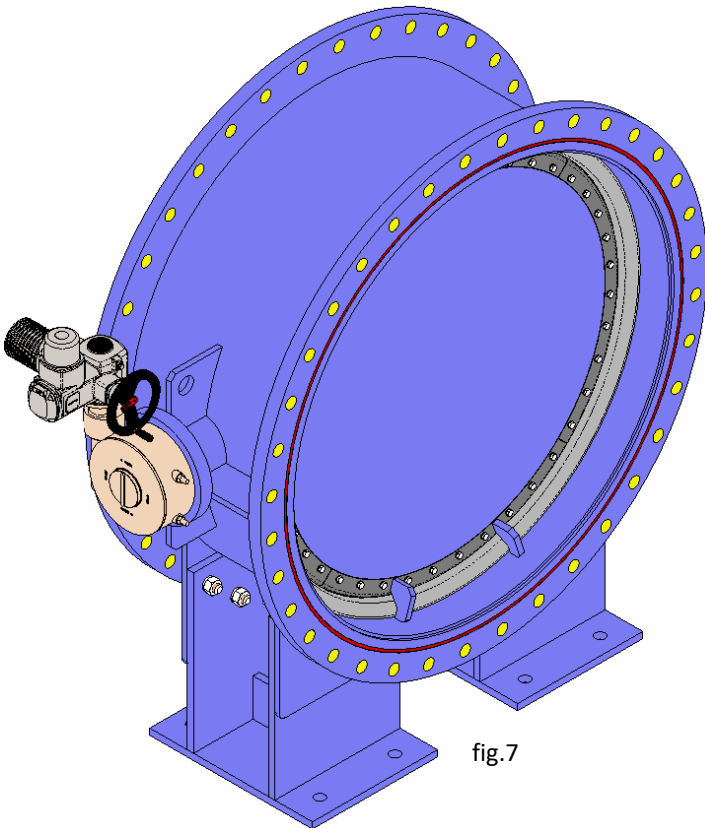

fig.7
Motorised
Geared
Actuator

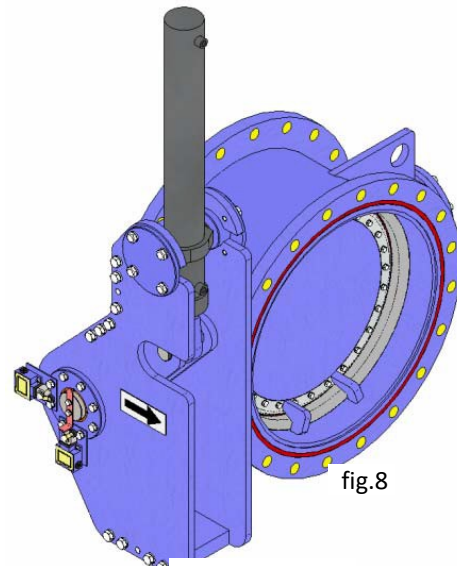

fig.8
Double-Acting
Hydraulic
Actuator

BUTTERFLY VALVE

ME SERIES

MAINTENANCE

CMO will not be liable if the valves suffer any damage due to improper handling or without proper authorisation. The valves must not be modified except under express authorisation from CMO. In order to avoid personal or material damage when performing the maintenance tasks, it is recommended to follow these instructions:



- The staff responsible for the maintenance or operation of the equipment must be qualified and trained.
- Use suitable Personal Protective Equipment (PPE) (gloves, safety boots, goggles...).
- Shut off all lines that affect the valve and put up a warning sign to inform about the work being performed.
- Completely isolate the valve from the whole process. Depressurise the process.
- Drain all the line fluid through the valve.
- Use manual rather than electric tools during the maintenance, in accordance with **EN13463-1(15)**.

The only maintenance required in this type of valve is to change the shaft O-rings and sealing rubber. It is recommended to regularly check the seal every 12 months, however its working life will depend on the valve's working conditions, such as pressure, temperature, number of operations, fluid composition, among others.

IMPORTANT SAFETY ASPECTS

- In order to work in ideal safety conditions, both the counterweights and the electric and magnetic elements must be idle. The electrical control cabinets must also be out of service. The maintenance staff must be up to date with the safety regulations and work can only start under orders from the site's safety staff.
- The safety areas must be clearly marked and you must avoid placing auxiliary equipment (ladders, scaffolding, etc.) on levers or moving parts which may lead to the movement of the clapper.
- In equipment with counterweight actuators, the clapper must be mechanically locked and only released when maintenance work is complete and the actuator is reconnected.
- In equipment with an electric actuator, it is recommended to disconnect it from the mains in order to access the moving parts without any risk.
- Due to its great importance, you must check that the valve shaft has no load before disassembling the actuator system.

Taking into account the recommendations indicated, below are the maintenance operations most commonly carried out in this type of equipment:

REPLACING THE SEALING JOINT

Regularly check the seals and seats, replacing them in the event of deterioration or absence of seal tightness.

1. Make sure there is absolutely no pressure and fluid in the facility.
2. Shut off the valve completely
3. Remove the valve, the pipeline (not necessary when over DN-800).

BUTTERFLY VALVE

ME SERIES

4. Open the valve completely.
5. Mark the original positions of the stainless steel flange sectors (4) which secure the seal (3) in the clapper (2).
6. Release all the screws (29, 30) which secure the flange (4).
7. Remove all the flange sectors (4).
8. Remove the deteriorated seal (3).
9. Clean the fittings for the clapper (2) and flange seals (4).
10. Check that the dimensions of the new seal (3) are exactly the same as the replaced one.
11. Cut the new seal (3) with the correct length.
12. Before installing the seal (3) in the clapper (2), glue the ends of the seal (3) together with high resistance glue such as Loctite.
13. Position the new seal (3) in the clapper (2).
14. Return the flange sectors (4) to the original position.
15. Screw the flange seal diametrically (4).
16. Perform several manoeuvres with no load, checking the correct operation of the valve.
17. Shut off the valve completely.
18. Reinstall the valve in the duct (not necessary when over DN-800).
19. Pressurise the valve in the line and check seal tightness.

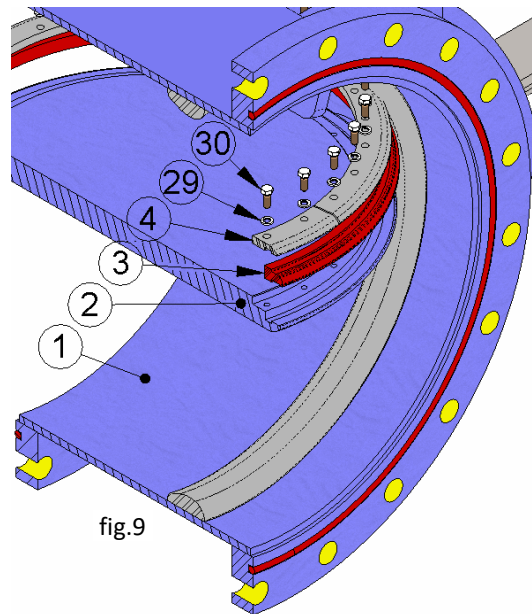

 **Note:** The numbers in brackets refer to the image in figure 9.

 **Note:** During the assembly of the new sealing joint it is recommended to apply "Vaseline" to the seal to facilitate the assembly process and the correct operation of the valve (do not use oil or grease); table 2 below shows details of the Vaseline used by CMO:

PETROLEUM JELLY		
Saybolt colour	ASTM D-156	15
Melting point (°C)	ASTM D-127	60
Viscosity at 100°C	ASTM D-445	5
Penetration 25°C mm./10	ASTM D-937	165
Silicone content	None	
Pharmacopeia BP	OK	

table 2

REPLACING THE O-RINGS

Regularly check the shaft O-rings, replacing them in the event of deterioration or absence of seal tightness.

It is not necessary to remove the duct valve, since the change can be carried out with the valve mounted in the facility. This valve has O-rings on both shafts, and these are changed in a different way. Do not use sharp tools during this process.

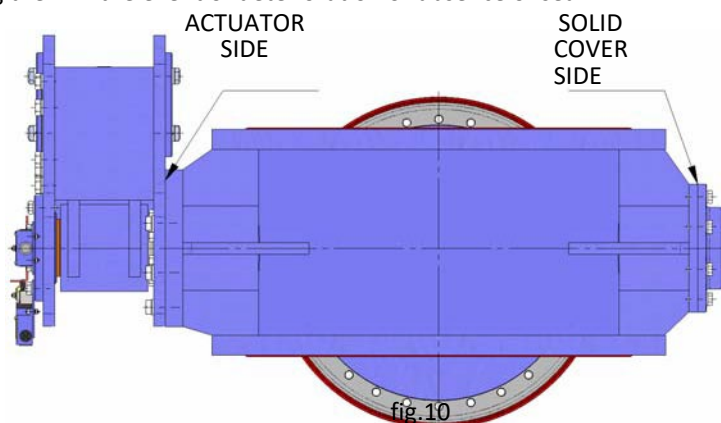

BUTTERFLY VALVE

ME SERIES

ACTUATOR SIDE

ACTUATOR UNIT

1. Make sure there is absolutely no pressure and fluid in the facility.
2. Shut off the valve to ensure the clapper is idle.
3. Before releasing any part, always mark its original position.
4. Release the whole actuator unit.
5. Release the guide cover (22) and remove it from the shaft.
6. Remove the deteriorated O-rings (21).
7. Clean the O-ring housing.
8. Position the new O-rings (21) on the guide cover.
9. Insert the guide cover (22) in the shaft and return to the original location.
10. Screw the guide cover (22) diametrically.
11. Mount the actuator unit in its original position.
12. Perform several manoeuvres with no load, checking the correct operation of the valve.
13. Pressurise the valve in the line and check there are no leakages around the shaft.

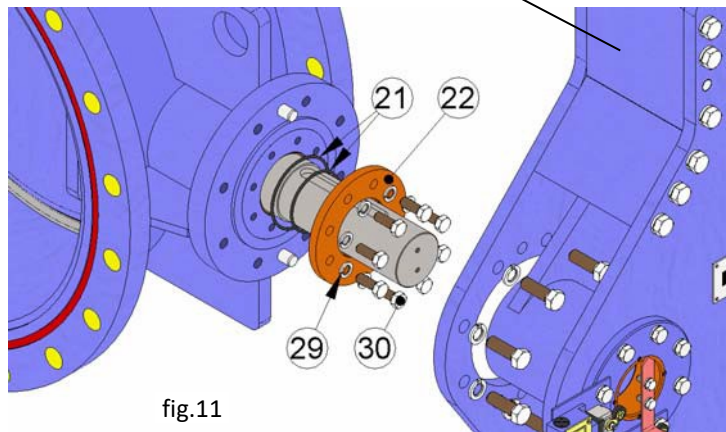

fig.11

 **Note:** The numbers in brackets refer to the image in figure 11.

SOLID COVER SIDE

1. Make sure there is absolutely no pressure and fluid in the facility.
2. Before releasing any part, always mark its original position.
3. Release the solid cover (20) and remove it from the valve.
4. Remove the deteriorated O-ring (19).
5. Clean the O-ring housing.
6. Position the new O-ring (19) on the solid cover (20).
7. Position the solid cover (20) in its original valve location.
8. Screw the solid cover (20) diametrically.
9. Perform several manoeuvres with no load, checking the correct operation of the valve.
10. Pressurise the valve in the line and check there are no leakages through the solid cover (20).

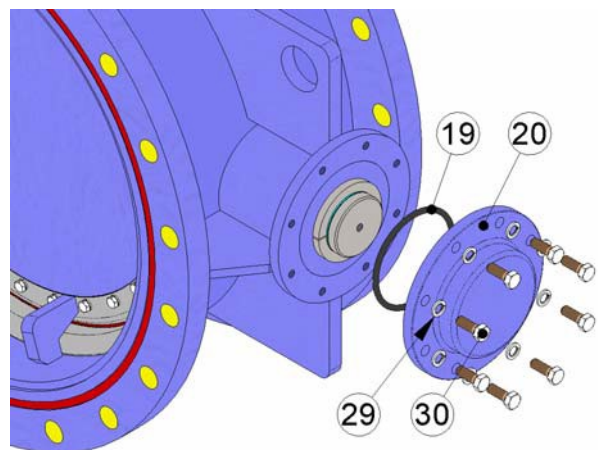



fig.12

 **Note:** The numbers in brackets refer to the image in figure 12.

STORAGE

To ensure the valve is in optimum conditions of use after long periods of storage, it should be stored in a well-ventilated place at temperatures below 30°C.

It is not advisable, but if it is stored outside, the valve must be covered to protect it from heat and direct sunlight, with good ventilation to prevent humidity. The following aspects must be considered for storage purposes:

- The storage place must be dry and under cover.
- It is not recommended to store the equipment outdoors with direct exposure to adverse weather conditions, such as rain, wind, etc.
- This recommendation is even more important in areas with high humidity and saline environments. Wind can carry dust and particles which can come into contact with the valve's moving parts and this can lead to operating difficulties. The actuator system can also be damaged due to the introduction of particles in the different elements.
- The equipment must be stored on a flat surface to avoid deformations.
- If the equipment is stored without suitable packaging it is important to keep the valve's moving parts lubricated, for this reason it is recommended to carry out regular checks and lubrication.
- Likewise, if there are any machined surfaces without surface protection it is important for some form of protection to be applied to prevent the appearance of corrosion.

BUTTERFLY VALVE

ME SERIES

COMPONENTS LIST (Hydraulic Actuator)

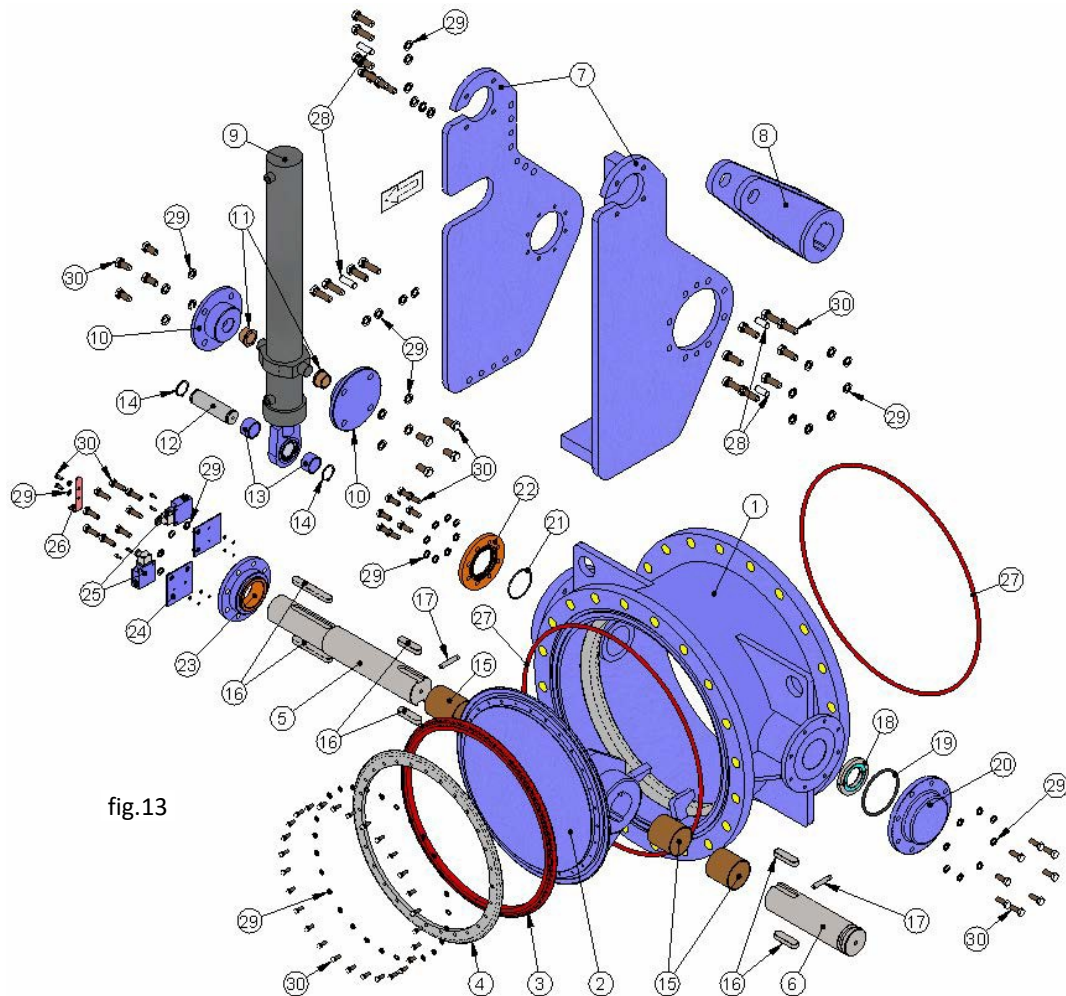

STANDARD COMPONENTS LIST			
POS.	COMPONENT	POS.	COMPONENT
1	BODY	16	COTTER
2	CLAPPER	17	PIN
3	SEAL	18	FRICTION WASHER
4	FLANGE SEAL	19	RUBBER RING
5	DRIVE SHAFT	20	SOLID COVER
6	SHAFT	21	RUBBER RING
7	ACTUATOR SUPPORT	22	GUIDE COVER
8	ACTUATOR ARM	23	SUPPORT COVER
9	ACTUATOR	24	LIMIT SWITCH SUPPORT
10	SUPPORT COVER	25	LIMIT SWITCH
11	BUSH BEARING	26	POSITION INDICATOR
12	PIN	27	O-RING SEAL
13	DISTANCER BUSHING	28	PIN
14	CIR-CLIP	29	WASHER
15	BUSH BEARING	30	SCREW

table 3

C.M.O.