

R



INSTRUCTIONS AND MAINTENANCE MANUAL



INSTRUCTIONS AND MAINTENANCE MANUAL

ASSEMBLY

APPLICATION OF EUROPEAN DIRECTIVES

See document of European Directives applicable to **CMO Valves**.



Valve **R** complies with the Directive on Equipment and Protective Systems for Potentially Explosive Atmospheres. In these cases the logo will appear on the identification label. This label shows the exact classification of the zone in which the valve can be used. The user is responsible for its use in any other zone.

HANDLING

When handling the equipment please pay special attention to the following points:

- **SAFETY WARNING:** Before handling the valve check that the crane to be used is capable of bearing its weight.
- To prevent damage, especially to the anticorrosive protection, it is recommended to use soft straps to lift the **CMO valves**. These straps must be fitted to the top of valve, in the intended strap.
- Do not lift the valve or hold it by the actuator (in case that it have). Lifting the valve by the actuator can lead to operating problems as it is not designed to withstand the valve's weight.
- Do not lift the valve or hold it by the flow passage area. The valve's seat is located in this area. If the valve is held and lifted by this area it can damage the surface and the seat and lead to leakage problems while the valve is operating.



Fig. 1

INSTALLATION

In order to avoid personal harm and other type of damage (to property, the plant, etc.) please follow these recommendations:

- The staff responsible for the handling and maintenance of the equipment must be qualified and trained in operations with this type of equipment.
- Use suitable Personal Protective Equipment (PPE) (gloves, safety boots, goggles, helmet, reflective vest...).
- Shut off all operating lines to the valve and put up a warning sign.
- Completely isolate the valve from the whole process.
- Depressurise the process.
- Drain all the line's fluid through the valve.
- Use hand tools not electric tools during the installation and maintenance, in according to current regulations.



Before installation, inspect the valve body and components for any possible damage occurred during transport or storage. Make sure that the valve's inside cavities are clean. Inspect the pipes and the flanges to make sure they contain no foreign material and are clean.

The R valve is **unidirectional** and an arrow is marked on the body indicating the flow direction

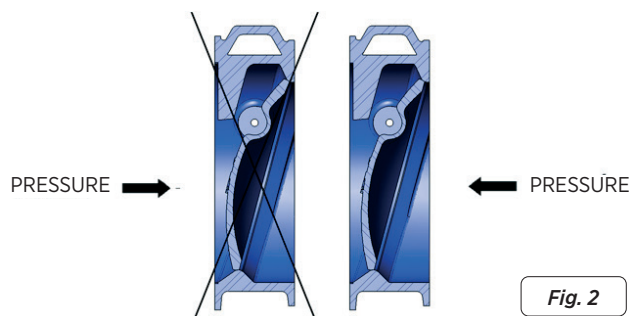

Fig. 2

ADVANTAGE

CONSIDER DURING ASSEMBLY

The minimum distances in the installation are as follows:

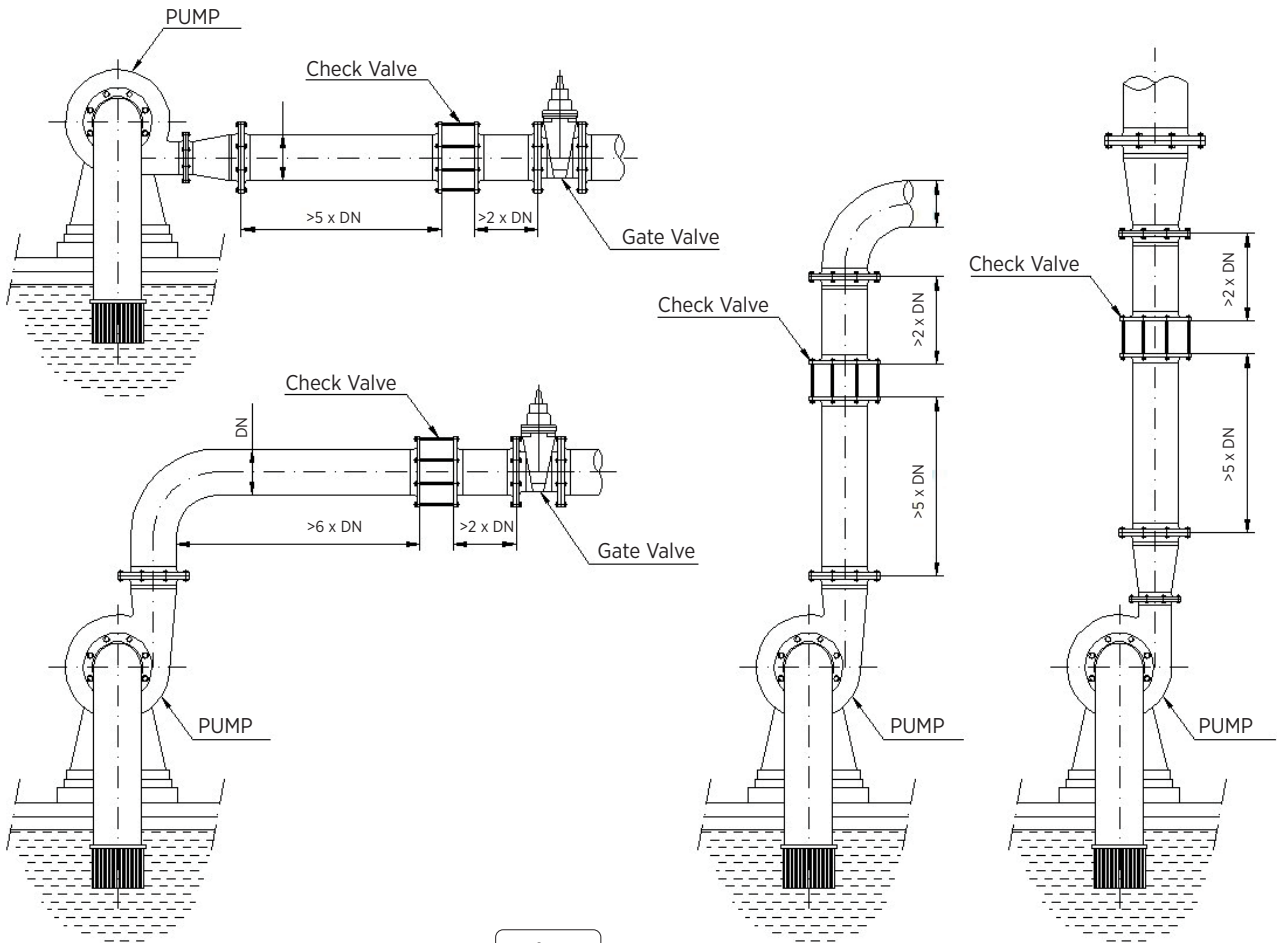

Fig. 3

Special care must be taken to maintain the correct distance (gap) between the flanges and ensure they are correctly aligned and parallel (fig. 4). The incorrect position or installation of the flanges can cause deformations on the valve's body which can cause difficulties during operation.

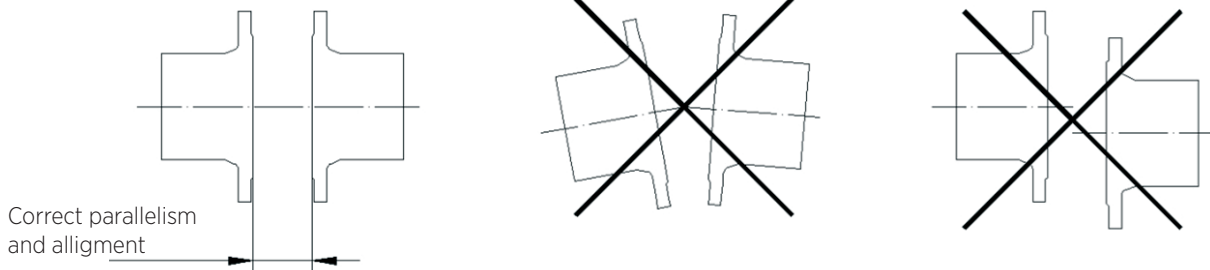

Fig. 4

It is very important to make sure that the valve is correctly aligned and parallel to the flanges to prevent leakages and avoid deformations.

ASSEMBLY POSITIONS

The following aspects must be considered:

- The use of disassembly reels is recommended which make the installation and possible future maintenance of the valve easier.
- To ensure the valve's perfect operation, a minimum distance of straight conduit must be kept after the piping, for the free operation of the valve (fig. 3).
- The piping should never be placed in downward flow.
- When we assemble the valve in the circuit, we will pay special attention to ensure the valve's stem is perpendicular to the horizontal plane.
- When the valve has a counterweight, we can assemble the valve in any of the 3 positions indicated in fig. 4, but the counterweight will always turn +45° to -45° to the horizontal plane, if necessary, we will move it.



Once the valve is installed in its place, check the fastenings, flanges, electrical or pneumatic connections. If electrical connections are present or you are in an ATEX zone, earth connections must be made before starting.

In an ATEX zone, check the continuity between the valve and the pipeline (EN 12266-2, annex B, points B.2.2.2. and B.2.3.1.). Check the pipeline's earth connection and the conductivity between the outlet and inlet pipelines.

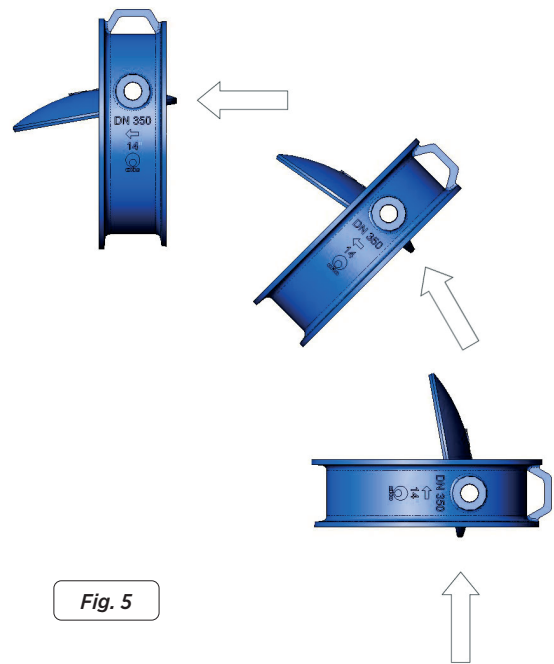

Fig. 5

ACCESSORIES

STANDARD (Fig. 6):

The valve's disc is opened by the fluid passing through and it closes due to the weight of the disc and the return of the fluid.

WITH SPRING:

The same system as the standard but with a spring on the stem which helps the closing process.

WITH COUNTERWEIGHT:

With a counterweight on one end of the stem which will generate a larger initial closing torque.



Fig. 6

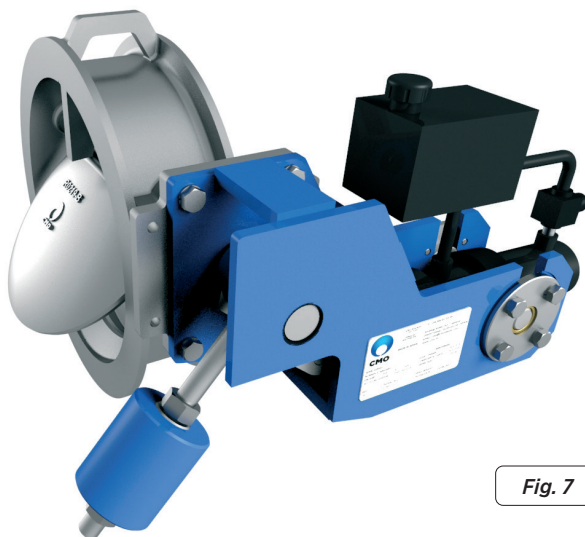

Fig. 7

HYDRAULIC WITH DAMPER (Fig. 7):

When the valve closing produces a high impact, due to the load and the valve's diameter, it is possible to install a damper.

THE HYDRAULIC DAMPER INCLUDES:

Cylinder, accumulator tank and flow regulator. This acts throughout the valve closing and the closing speed can be regulated, however, it does not act throughout the opening. The hydraulic circuit is closed.

The counterweight is used to achieve an even larger initial closing torque.

These valves are not designed to work in intermediate positions and must be regulated by specialised personnel, who will consider the following points:

- Check the oil level of the hydraulic circuit.
- For empty regulation, the valve must be opened manually, the flow regulator must be fully opened and then closed gradually until the closing speed is adjusted.
- For regulation of the valve in the installation in operation, start with the flow regulator in intermediate position and then gradually open or close it by adjusting the actuator speed.

To avoid problems such as stopping the disk in intermediate positions, avoid fully closing the flow regulator, leaving a slight margin for subsequent readjustments.

These valves are not designed to work with the disk in intermediate positions, which is why the axes are designed to resist the maximum working pressure exclusively in open or closed position. Due to, the back pressure that these valves can resist in intermediate positions is less than the maximum working pressure and is specified in the following table.

DN (mm)	150	200	250	300	350	400	450	500	600	700	800
Contrapresión (bar)	5	5	3	3	3	2.5	2.5	2.5	2	2	2

Tabla 1

Besides the backpressure that these valves can work, we must also take into account the closing time factor, which should not exceed 8 seconds.

MAINTENANCE

R valves need practically no maintenance, only a regular operation check, the most demanding ones as regards maintenance are hydraulic with damper valves, which require the following:

Regular check of their side covers. In the event of leakages, re-tighten the screws or replace O-rings if necessary

Regularly check the hydraulic dampening: Oil level. It is recommended to use oil with a kinematic viscosity of 30 to 50 mm²/s (ISO 22 grade).

Check over the connections of the hydraulic circuit, to ensure all the components are tightened.

In order to avoid personal harm and other types of damage (to the plant, etc.) please follow these recommendations:

- The staff member responsible for the installation, operation and maintenance of the valves must be qualified and trained in the operation of similar valves.
- Appropriate personal protection must be used (gloves, safety boots, goggles, helmet...).
- Shut off all operating lines to the valve and put up a warning sign.
- Completely isolate the valve from the process.
- Fully depressurise the process.
- Drain all the line's fluid through the valve.
- Use hand tools not electric tools during the installation and maintenance, in according to current regulations.

In an ATEX zone, electrostatic charges may be present inside the valve, which can cause explosions. The user is responsible for minimising the risks.

- The maintenance staff must consider the risks of explosion and ATEX training is recommended
- If the fluid transported constitutes an internal explosive atmosphere, the user must regularly check the installation's correct watertight integrity.
- Regular cleaning of the valve to prevent accumulation of dust.
- Assemblies not permitted at the end of the line.
- Avoid painting the products supplied

After the maintenance is complete, in an **ATEX** zone it is obligatory to check the electrical continuity between the pipeline and the rest of the installation's components. EN 12266-2, annex B, points B.2.2.2. and B.2.3.1.).

STORAGE

To ensure the valve is in optimum conditions of use after long periods of storage, it should be stored in a well-ventilated place at temperatures below 30°C.

If it is stored outside, the valve must be covered to protect it from heat and direct sunlight, with good ventilation to prevent humidity.

COMPONENTS LIST



Fig. 8

STANDARD VERSION	
POS.	DESCRIPTION
1	BODY
2	DISC
3	STEM
4	CAP

Tabla 2

COMPONENTS LIST

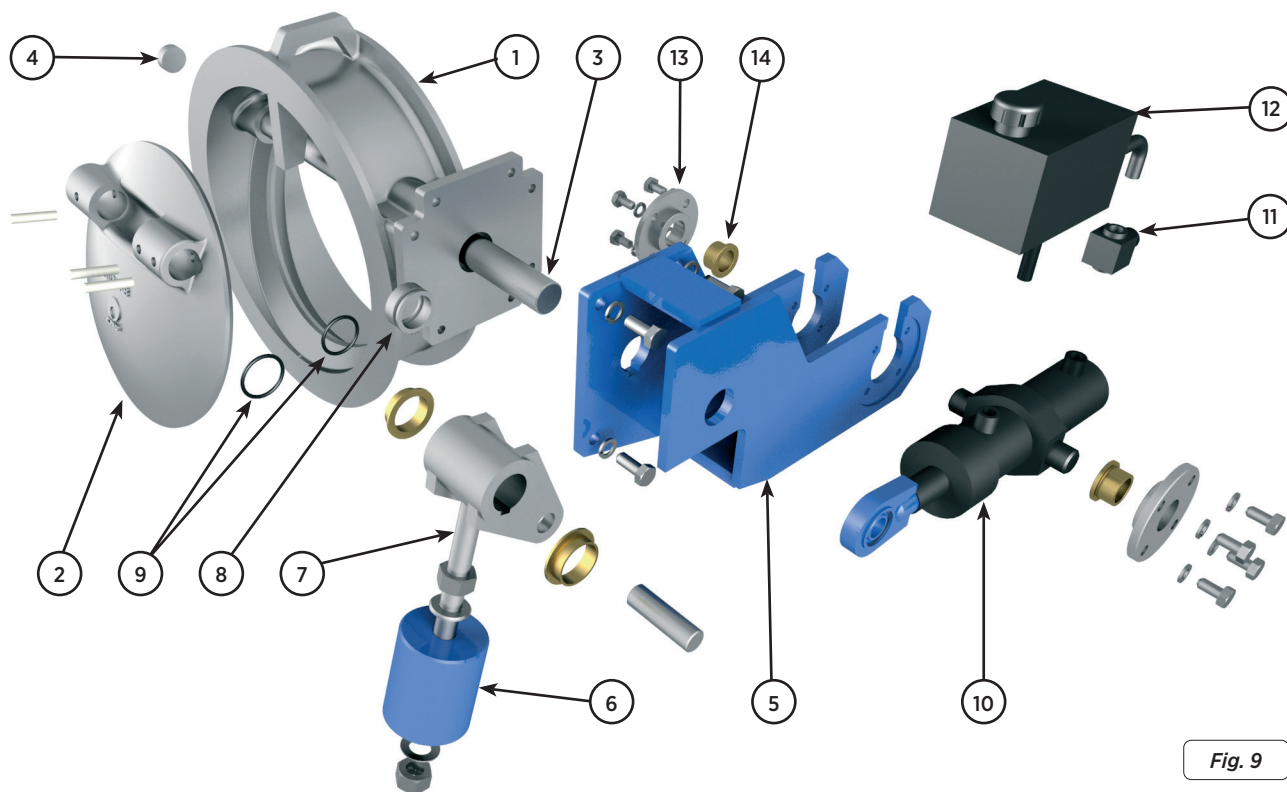

Fig. 9

COUNTERWEIGHT + SHOCK ABSORBER VERSION	
POS.	DESCRIPTION
1	BODY
2	DISC
3	STEM
4	CAP
5	SUPPORT
6	COUNTERWEIGHT
7	LEVER
8	SOCKET
9	JOINT
10	CYLINDER
11	REGULATOR
12	TANK
13	CYLINDER COVER
14	CYLINDER SOCKET

Tabla 3



www.cmovalves.com



CMO VALVES

QMS CERTIFIED BY LRQA
Approval number ISO9001 0035593

CMO VALVES
HEADQUARTERS MAIN
OFFICES & FACTORY

Amategi Aldea, 142
20400 Tolosa
Gipuzkoa (Spain)

Tel.: (+34) 943 67 33 99

cmo@cmovalves.com
www.cmovalves.com

CMO VALVES
MADRID

C/ Rumania, 5 - D5 (P.E. Inbisa)
28802 Alcalá de Henares
Madrid (Spain)

Tel.: (+34) 91 877 11 80

cmomadrid@cmovalves.com
www.cmovalves.com

CMO VALVES
FRANCE

5 chemin de la Brocardière
F-69570 DARDILLY
France

Tel.: (+33) 4 72 18 94 44

cmofrance@cmovalves.com
www.cmovalves.com