



CONSTRUCCIONES
METÁLICAS
DE OBTURACIÓN, S.L.

CMO



GESTION DE
LA CALIDAD
CERTIFICADA

QUALITY
MANAGEMENT
CERTIFIED

KNIFE GATE VALVES

SERIES FK

04/09/2014

INSTRUCTIONS AND MAINTENANCE MANUAL

SERIES: FK

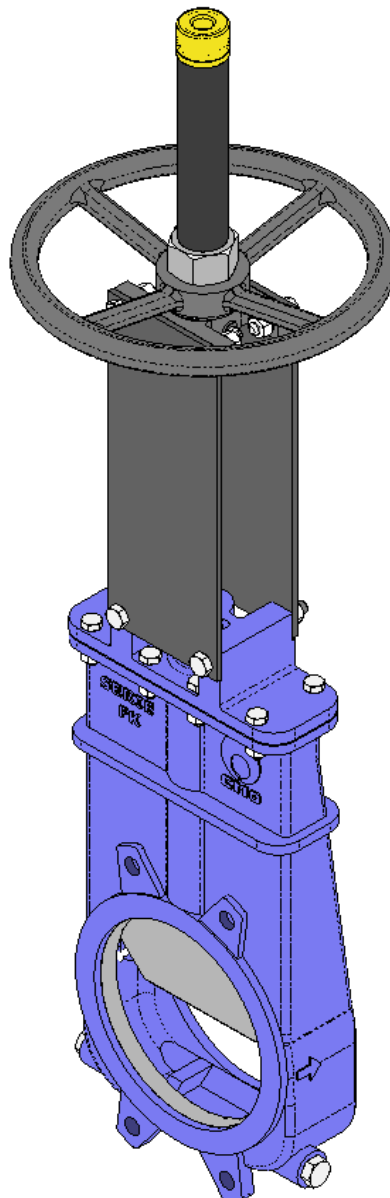

C.M.O.

Amategui Aldea 142, 20400 Txarama-Tolosa (SPAIN)

MAN-FK.EN02

Tel. National: 902.40.80.50 Fax: 902.40.80.51 / Tel. International: 34.943.67.33.99 Fax: 34.943.67.24.40

cmo@cmo.es <http://www.cmo.es>

Page 1

ASSEMBLY

THE FK VALVE COMPLIES WITH THE FOLLOWING:

Machinery Directive: **DIR 2006/42/EC (MACHINERY)**

Pressure Equipment Directive: **DIR 97/23/EC (PED) ART.3, P.3**

Potentially Explosive Atmospheres Directive (optional): **DIR 94/9/EC (ATEX) CAT.3 ZONE 2 and 22 GD.**

The **FK** valve complies with the Directive on Equipment and Protective Systems for Potentially Explosive Atmospheres. In these cases the logo will appear on the identification label. This label shows the exact classification of the zone in which the valve can be used. The user is responsible for its use in any other zone.



HANDLING

When handling the equipment please pay special attention to the following points:

- **SAFETY WARNING:** Before handling the valve, check that the crane to be used is capable of bearing its weight.
- To prevent damage, especially to the anticorrosive protection, it is recommended to use soft straps to lift the CMO knife gate valves. These straps must be fitted around the top of body.
- Do not lift the valve or hold it by the actuator. Lifting the valve by the actuator can lead to operating problems as it is not designed to withstand the valve's weight.
- Do not lift the valve by holding it in the flow passage area. The valve's seal is located in this area. If the valve is held and lifted by this area it can damage the surface and the O-ring seal and lead to leakage problems whilst the valve is operating.
- Packing in wooden boxes: If the equipment is packed in wooden boxes these must be provided with clearly marked holding areas where the slings will be placed when securing them. In the event that two or more valves are packed together, separation and securing elements must be provided between them to prevent possible movements, knocks and friction during transport. When storing two or more valves in the same box you must ensure they are correctly supported to prevent deformations. In the case of dispatches by sea we recommend the use of vacuum bags inside the boxes to protect the equipment from contact with sea water.
- Pay special attention to maintaining the correct levelling of the valves during loading and unloading as well as during transport to prevent deformations in the equipment. For this purpose we recommend the use of mounts or trestles.



INSTALLATION

In order to avoid personal harm and other type of damage (to the facilities, the valve, etc.) please follow these instructions:

- The staff responsible for the installation or operation of the equipment must be qualified and trained.
- Use suitable Personal Protective Equipment (PPE) (gloves, safety boots, goggles...).
- Shut off all lines that affect the valve and put up a warning sign to inform about the work being performed.
- Completely isolate the valve from the whole process. Depressurise the process.
- Drain all the line fluid through the valve.
- Use manual rather than electric tools during the installation and maintenance, in accordance with **EN13463-1(15)**.



KNIFE GATE VALVES

SERIES FK

Before installation, inspect the valve to ensure no damage has occurred during transport or storage.

Make sure that the inside of the valve body and, in particular, the seal area are clean. Inspect the installation's pipes and the flanges to make sure they are clean.

ASPECTS TO BE CONSIDERED DURING ASSEMBLY

The FK valve is unidirectional and an arrow is marked on the body indicating the flow direction.

The word SEAT is also marked on one side of the body (near the packing gland) to indicate the side where the sealing joint is located.

The normal working position of the FK valve is indicated in Fig. 1.

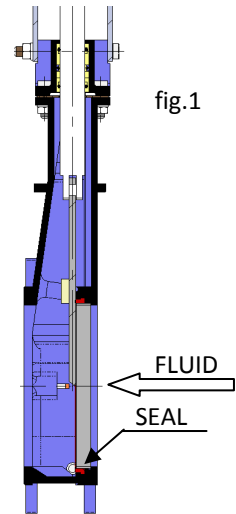

- Special care must be taken to respect the correct distance between the flanges and ensure they are correctly aligned and parallel (fig. 2).

The incorrect position or installation of the flanges can cause deformations on the valve's body and this could lead to operating problems.

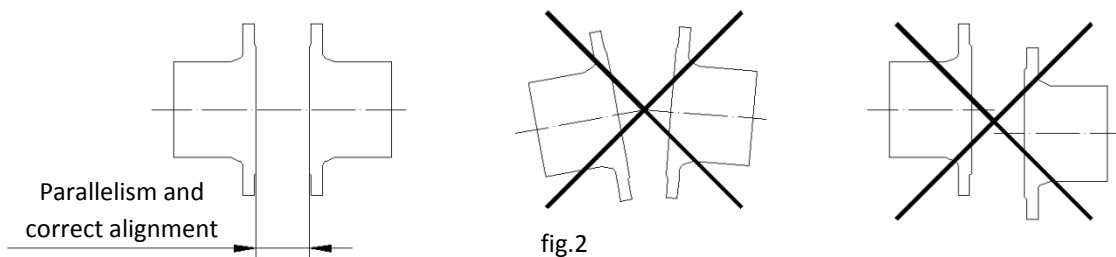

It is very important to make sure that the valve is correctly aligned and parallel to the flanges to prevent leakages and avoid deformations. Ensure the valve is assembled in open position.

- The screws in the tapped blind holes will have a maximum depth (fig. 3) and will never reach the bottom of the hole. The following table (table 1) shows the maximum thread depth in the holes and the maximum torque to be applied to the flange screws:

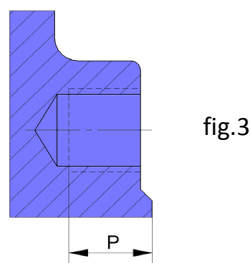

DN	50	65	80	100	125	150	200	250	300	350	400	450	500	600	700	800	900	1000	1200
P	8	8	10	10	10	12	10	12	12	21	21	21	21	20	25	22	21	21	30
TORQUE (Nm)	45	45	45	45	45	88	88	88	88	88	152	152	152	223	223	303	303	412	529

table 1



KNIFE GATE VALVES

SERIES FK

- The equipment must be firmly installed in the duct. It will be joined to the duct with a screw joint.
- The screws and nuts to be fitted must also be suitable for the operating conditions and their measurements must be in accordance with the approved plans. The screws and nuts must be fitted diametrically. The torque to apply to the fastening screws and nuts must be correct according to the applicable standard, we recommend the initial assembly be carried out with a low tightening torque and after all the screws are in place, the final torque is applied.
- As regards scaffolding, ladders and other auxiliary elements to be used during the assembly, follow the safety recommendations indicated in this dossier.
- Once the equipment has been assembled make sure that there are no elements, whether interior or exterior, which can interfere with the movement of the knife gate.
- Make the relevant connections (electrical, pneumatic, hydraulic) in the equipment's actuator system following the instructions and wiring diagrams supplied with it.
- The operation of the equipment must be coordinated with the site's control and safety staff and no modifications are permitted in the equipment's external indication elements (limit switches, positioners, etc.).
- When operating the equipment, follow the safety recommendations indicated in this dossier.

ASSEMBLY POSITIONS

This valve is mainly designed for silo discharges, which is why it is usually assembled in horizontal position, as shown in the following diagram (fig 4).

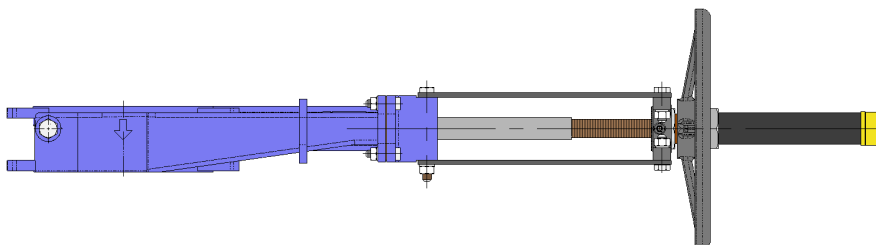

fig.4

It is generally assembled under the hopper. This assembly position and the shape of the inside of the body ensure that no solids accumulate inside, and allow the product to flow easily through the valve.

It can also be assembled vertically in the horizontal pipe, in both cases it is recommended to assemble them with the joints between the flanges, to ensure sealtight integrity between the flanges and the valve.

Once the valve has been installed, check that all the screws and nuts have been correctly tightened and that the whole valve action system has been correctly adjusted (electrical connections, pneumatic connections, instruments...).

All CMO valves are tested at its facilities, however, during handling and transport the screws on the packing gland can come loose and must be re-tightened whenever the valve is supplied with a gasket and packing gland system. Once the valve is installed in the pipeline and has been pressurised, it is very important to check whether there is any leakage from the packing gland to the exterior, and, in the event of leakage, it is necessary to tighten the screws of the packing gland crosswise until the leakage disappears, taking into account that there should be no contact between the packing gland flange and the rod.

A very high tightening torque on the packing gland's screws can lead to problems, such as an increase in the torque required to drive the valve, reduction in the gasket's working life, or the breaking of the packing gland. The tightening torques are indicated in Table 2.

Tightening torques for packing gland screws	
DN50 to DN125	25 Nm
DN150 to DN300	30 Nm
DN350 to DN1200	35 Nm

table 2

Once the valve is installed in its place, check that the flanges and electrical and pneumatic connections are secure. If the valve has electrical accessories or you are in an ATEX zone, earth connections must be made before operating it.



If you are in an ATEX zone, check the continuity between the valve and the pipe (EN 12266-2, annex B, points B.2.2.2. Ind B.2.3.1.). Check the pipe's earth connection and the conductivity between the outlet and inlet pipes.

ACTUATOR

HANDWHEEL (rising stem, non-rising stem and with gear box)

To operate the valve: Turn the handwheel clockwise to close or anticlockwise to open.

CHAINWHEEL

To operate the valve pull one of the chain's vertical drops, taking into account that locking is carried out when the chainwheel turns clockwise.

LEVER

First loosen the position locking clamp located on the yoke. Once it is unlocked, raise the lever to open it or lower to close it. To complete the operation lock the lever again.

PNEUMATIC (double and single acting),

CMO pneumatic actuators are designed to be connected to a 6 kg/cm² pneumatic network, although these cylinders support up to 10 kg/cm².

The pressurised air used for the pneumatic actuator must be correctly filtered and lubricated.

This type of actuator does not require any adjustment, due to the fact that the pneumatic cylinder is designed for the exact stroke required by the valve.

HYDRAULIC (double and single acting)

CMO hydraulic actuators are designed to work at a standard pressure of 135 kg/cm².

This type of actuator does not require any adjustment, due to the fact that the hydraulic cylinder is designed for the exact stroke required by the valve.

MOTORISED (rising or non-rising stem)

If the valve incorporates a motorised actuator it will be accompanied with the electric actuator supplier's instructions.

KNIFE GATE VALVES

SERIES FK

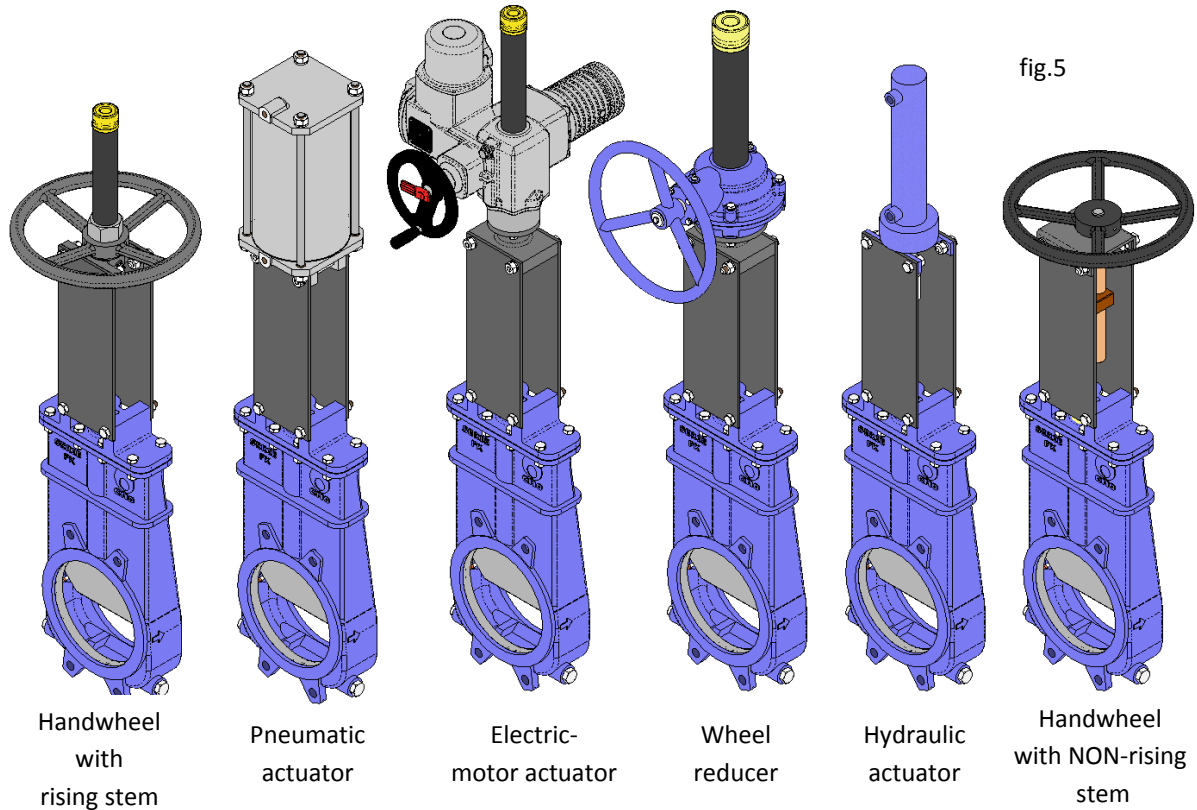

MAINTENANCE

CMO will not be liable if the valves suffer any damage due to improper handling or without proper authorisation. The valves must not be modified except under express authorisation from CMO.

In order to avoid personal or material damage when performing the maintenance tasks, it is recommended to follow these instructions:

- The staff responsible for the maintenance or operation of the equipment must be qualified and trained.
- Use suitable Personal Protective Equipment (PPE) (gloves, safety boots, goggles...).
- Shut off all lines that affect the valve and put up a warning sign to inform about the work being performed.
- Completely isolate the valve from the whole process. Depressurise the process.
- Drain all the line fluid through the valve.
- Use manual rather than electric tools during the maintenance, in accordance with **EN13463-1(15)**.



The maintenance required in this type of valve is to change the seat's rubber joint (if soft seat is used), joint (between body and cover) and the gasket (if fitted) or closing bushing. It is recommended to regularly check the seal every 6 months, however its working life will depend on the valve's operating conditions, such as: pressure, temperature, number of operations, type of fluid and others.



In an ATEX zone, electrostatic charges may be present inside the valve, which can cause a risk of explosion. The user will be responsible for carrying out the appropriate actions in order to minimise the risks.

C.M.O.

Amategui Aldea 142, 20400 Txarama-Tolosa (SPAIN)

MAN-FK.EN02

Tel. National: 902.40.80.50 Fax: 902.40.80.51 / Tel. International: 34.943.67.33.99 Fax: 34.943.67.24.40

cmo@cmo.es <http://www.cmo.es>

Page 6

KNIFE GATE VALVES

SERIES FK



- The maintenance staff must be informed about the risks of explosion and ATEX training is recommended.
- If the fluid transported constitutes an internal explosive atmosphere, the user must regularly check the installation's correct seal tightness.
- Regularly clean the valve to prevent accumulation of dust.
- Assemblies are not permitted at the end of the line.
- Avoid re-painting the products supplied.

IMPORTANT SAFETY ASPECTS

- In order to work under ideal safety conditions, the magnetic and electrical elements must be in idle mode and the air tanks depressurised. The electrical control cabinets must also be out of service. The maintenance staff must be up to date with the safety regulations and work can only start under orders from the site's safety staff.
- The safety areas must be clearly marked and you must avoid placing auxiliary equipment (ladders, scaffolding, etc.) on levers or moving parts which will lead to the movement of the knife gate.
- In equipment with spring return actuators, the knife gate valve must be mechanically locked and only unlocked when the actuator is pressurised.
- In equipment with electrical actuator, it is recommended to disconnect it from the mains in order to access the moving parts without any risk.
- Due to its great importance, you must check that the valve shaft has no load before disassembling the actuator system.

Taking into account the recommendations indicated, below we indicate the maintenance operations carried out in this type of equipment:

REPLACING THE SEALING JOINT (sealtight valves)

1. Make sure there is absolutely no pressure and fluid in the installation.
2. Remove the valve from the pipeline.
3. Use the actuator to operate the valve, leaving it in open position.
4. Clean the inside surfaces of the valve.
5. Remove the ring (14) that secures the sealing joint (13). To this end, apply a few sharp knocks to the outside with a bronze object at the base of the ring until it comes out.
6. Remove the old seal (13) and clean its housing.
7. Fit a new sealing joint (13) with the same dimensions as the old one or use the dimensions shown below (table 3).
8. Insert the retaining ring (14) in its original position as indicated:
 - Place the retaining ring (14) in perfect alignment parallel to the sealing joint.
 - Push the ring (14) as a whole towards the base of the channel.
 - Check that all areas of the ring (14) are correctly inserted, in perfect contact with the valve and the joint (13) has not been damaged in the process.
9. The valve assembly will be performed in exactly the opposite way to disassembly.

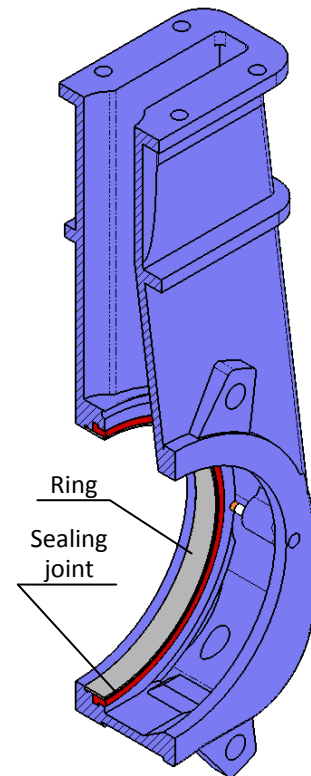

fig.6

 **Note:** The numbers in brackets refer to the components list in Table 7.

DN	50	65	80	100	125	150	200	250	300	350	400	450	500	600	700	800	900	1000	1200
Length (mm.)	190	250	290	370	445	530	690	845	1005	1175	1350	1520	1710	2020	2300	2680	3030	3367	3995

table 3

C.M.O.

Amategui Aldea 142, 20400 Txarama-Tolosa (SPAIN)

MAN-FK.EN02

Tel. National: 902.40.80.50 Fax: 902.40.80.51 / Tel. International: 34.943.67.33.99 Fax: 34.943.67.24.40

cmo@cmo.es <http://www.cmo.es>

Page 7

KNIFE GATE VALVES

SERIES FK

Note: During the assembly of the new sealing joint it is recommended to apply petroleum jelly to the seal to facilitate the assembly process and the correct operation of the valve (do not use oil or grease); table 4 below shows characteristics of the petroleum jelly used by CMO.

PETROLEUM JELLY		
Saybolt colour	ASTM D-156	15
Melting point (°C)	ASTM D-127	60
Viscosity at 100°C	ASTM D-445	5
Penetration 25°C mm./10	ASTM D-937	165
Silicone content	None	
Pharmacopeia BP	OK	

table 4

REPLACING THE SEALING JOINT (Teflon or PTFE)

You must follow the same operations that we have just described for the sealtight valves, but the following aspects must also be taken into account:

- To obtain greater sealtight integrity in the stainless steel bodies it is advisable to apply plastic glue to the joint housing. When the body is made of iron it is usually painted so this is not necessary.
- With the seal tab (13) pointing outwards, make a circle and then form a heart shape.
- It is recommendable to insert the joint in the top part, press the arched part and insert the seal into the housing.

REPLACING CLOSING BUSHING AND O-RINGS

1. Make sure there is absolutely no pressure and fluid in the installation.
2. Place the valve in close position.
3. Release actuator system leaving only the stem (15) protruding from the cover (3).
4. Loosen all the screws (24) which attach the body (1) to the cover (3).
5. Remove the cover (3) of the body (1).
6. Remove the closing bushing (5), along with the respective O-rings (7 and 8).
7. Replace the O-rings (7 and 8) and the closing bushing (5).
8. Before starting to assemble, we recommend applying petroleum jelly to the bushing (5) to facilitate the assembly and subsequent operation of the valve (do not use oil or grease); Table 4 (as mentioned above) shows the characteristics of the Vaseline used by CMO.
9. The valve assembly will be performed in exactly the opposite way to the disassembly.
10. Position the closing bushing (5) with the O-rings (7 and 8) and the stopper washer (6) in the original position.
11. Make sure the seat sealing joint (4) between the cover (3) and the body (1) is not damaged (if it is, replace it).
12. Carefully tighten the screws (24) of the cover (3) crosswise.
13. Assemble actuator system.
14. Perform several manoeuvres with no load, checking the correct operation of the valve.
15. Subject the valve to pressure in the line, checking that there are no leaks between the cover (3) and body (1), or between the rod (15) and the cover (3).

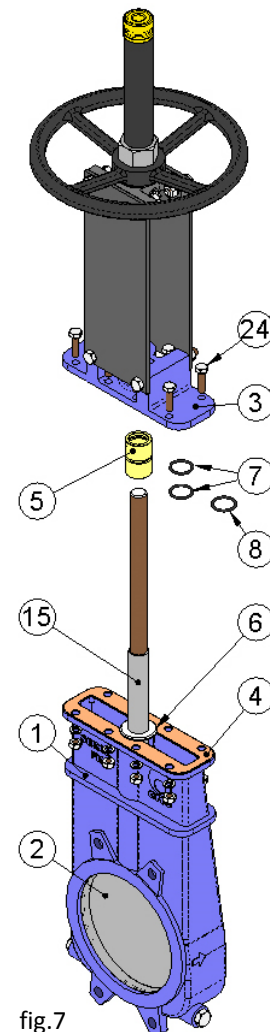

fig.7

Note: The numbers in brackets refer to fig. 7.

C.M.O.

Amategui Aldea 142, 20400 Txarama-Tolosa (SPAIN)

MAN-FK.EN02

Tel. National: 902.40.80.50 Fax: 902.40.80.51 / Tel. International: 34.943.67.33.99 Fax: 34.943.67.24.40

cmo@cmo.es <http://www.cmo.es>

Page 8

KNIFE GATE VALVES

SERIES FK

REPLACING SEAT SEALING JOINT (Between body and cover)

1. Make sure there is absolutely no pressure and fluid in the installation.
2. Place the valve in open position.
3. Loosen all the screws (24) which attach the body (1) to the cover (3).
4. Remove the actuator system, cover (3) and gate (2) of the body (1).
5. Remove the seat sealing joint (4) between the cover (3) and the body (1) and clean its accommodation.
6. Fit a new seat sealing joint (4) with the same dimensions as the old one.
7. The valve assembly will be performed in exactly the opposite way to the disassembly.
8. Make sure the seat sealing joint (4) is properly positioned between the cover (3) and the body (1) and introduce the assembly of the gate (2), cover (3) and actuator system in the body (1).
9. Carefully tighten the screws (24) of the cover (3) crosswise.
10. Perform several manoeuvres with no load, checking the correct operation of the valve.
11. Subject the valve to pressure in the line, checking that there are no leaks between the cover (3) and body (1), or between the rod (15) and the cover (3).

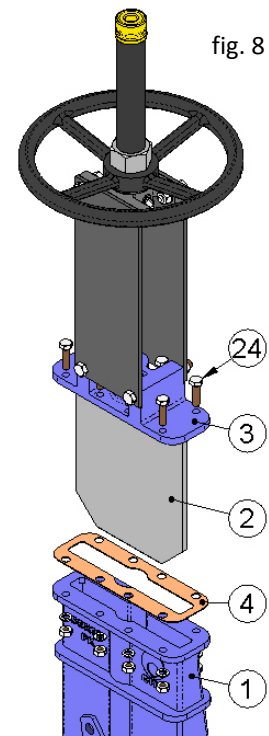



fig. 8

 **Note:** The numbers in brackets refer to fig. 8.

REPLACING THE GLAND (only in the case of gasket with packing gland)

1. Make sure there is absolutely no pressure and fluid in the installation.
2. Place the valve in open position.
3. Although not essential, for more comfort and more space to work it is advisable to release a support plate (11) as shown in fig. 9.
4. Loosen the nuts (28) and lift the packing gland flange (27) and the packing gland bushing (26) over the spindle.
5. Remove the old gasket (25) using a pointed tool, taking care not to damage the surface of the spindle (15).
6. Carefully clean the gasket, making sure there are no residues anywhere so the new gasket strips fit correctly.
7. Insert the new gasket (25). During this operation it is very important for both ends of each ring to be perfectly joined. Below we show the gasket dimensions (Table 5).
8. Place the packing gland bushing (26) and packing gland flange (27) in their original position, making sure not to touch the rod (15), carefully tighten all the nuts (28) crosswise, ensuring the same distance is left between the packing flange (27) and the rod (15) on both sides, then mount the support plate (11).
9. Perform several manoeuvres with no load, checking the correct operation of the valve and ensuring the packing gland is correctly aligned.
10. Pressurise the valve in the line and tighten the packing gland crosswise, enough to prevent leakages to the atmosphere.

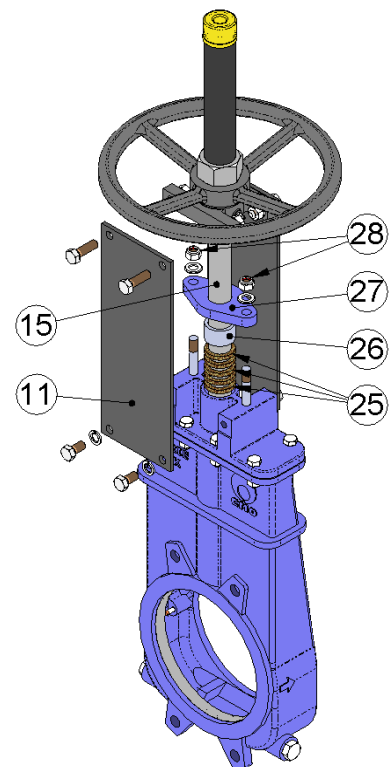

fig. 9

C.M.O.

Amategui Aldea 142, 20400 Txarama-Tolosa (SPAIN)

MAN-FK.EN02

Tel. National: 902.40.80.50 Fax: 902.40.80.51 / Tel. International: 34.943.67.33.99 Fax: 34.943.67.24.40

cmo@cmo.es <http://www.cmo.es>

Page 9

KNIFE GATE VALVES

SERIES FK

 **Note:** The numbers in brackets refer to fig. 9.

DN	50	65	80	100	125	150	200	250	300	350	400	450	500	600
Section (mm x mm)	6 x 6	6 x 6	6 x 6	6 x 6	6 x 6	6 x 6	6 x 6	8 x 8	8 x 8	8 x 8	8 x 8	8 x 8	8 x 8	8 x 8
Number of rings	5	5	5	5	5	5	4	4	5	5	5	5	5	5
Length (mm)	100	100	100	100	116	116	132	144	144	176	176	192	192	192

table 5

LUBRICATION

It is recommended to lubricate the stem twice a year by removing the protection cap and filling it with grease up to half its volume.



After the maintenance and in an ATEX zone, you must check the electrical continuity between the pipe and the rest of the valve's components, such as the body, through conduit, stem... EN 12266-2 Standard, annex B, points B.2.2.2. and B.2.3.1.)

MAINTAINING THE PNEUMATIC ACTUATOR

The pneumatic cylinders in our valves are manufactured and assembled at our premises. The maintenance of these cylinders is simple, if you need to replace any elements or have any questions please consult CMO. Below is an exploded diagram of the pneumatic actuator and a list of the cylinder's components. The top cover and the support cover are usually made of aluminium, although pneumatic cylinders greater than $\varnothing 200$ mm are made of cast iron GJS-400.

The maintenance kit normally includes: The bushing and its joints and the scraper, and, if the customer wishes, the piston is also supplied. Below we show the steps to follow to replace these parts.

1. Position the penstock in closed position and shut off the pneumatic circuit pressure.
2. Loosen the cylinder air input connections.
3. Release and remove the cylinder cap (5), the cylinder tube (4) and the tie rods (17).
4. Loosen the nut (15) which connects the piston (3) and the rod (1), remove the parts. Disassemble the cir-clip (11) and remove the bushing (8) with its joints (9 and 10).
5. Release and remove the cylinder head (2), in order to remove the scraper (6).
6. Replace the damaged parts with new ones and assemble the actuator in the reverse order to that described for disassembly.

KNIFE GATE VALVES

SERIES FK

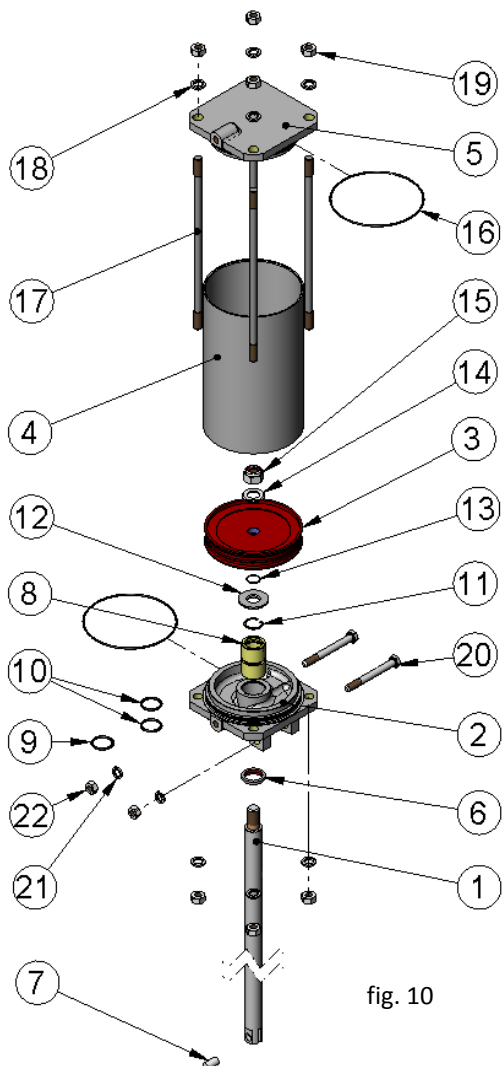

fig. 10

PNEUMATIC ACTUATOR		
POS.	DESCRIPTION	MATERIAL
1	STEM	AISI-304
2	SUPPORT COVER	ALUMINIUM
3	PISTON	S275JR + EPDM
4	CASING	ALUMINIUM
5	UPPER COVER	ALUMINIUM
6	SCRAPER	NITRILE
7	PIN	AISI-304
8	BUSHING	NYLON
9	EXTERIOR O-RING	NITRILE
10	INTERIOR O-RING	NITRILE
11	CIR-CLIP	STEEL
12	WASHER	ST ZINC
13	O-RING	NITRILE
14	WASHER	ST ZINC
15	SELF-LOCKING NUT	5.6 ZINC
16	O-RING	NITRILE
17	TIES	F-114 ZINC
18	WASHER	ST ZINC
19	NUT	5.6 ZINC
20	SCREW	5.6 ZINC
21	WASHER	ST ZINC
22	NUT	5.6 ZINC

table 6

STORAGE

To ensure the valve is in optimum conditions of use after long periods of storage, it should be stored in a well-ventilated place at temperatures below 30°C.

It is not advisable, but if it is stored outside, the valve must be covered to protect it from heat and direct sunlight, with good ventilation to prevent humidity. The following aspects must be considered for storage purposes:

- The storage place must be dry and under cover.
- It is not recommended to store the equipment outdoors with direct exposure to adverse weather conditions, such as rain, wind, etc., even when the equipment is packaged.
- This recommendation is even more important in areas with high humidity and saline environments. Wind can carry dust and particles which can come into contact with the valve's moving parts and this can lead to operating difficulties. The actuator system can also be damaged due to the introduction of particles in the different elements.
- The equipment must be stored on a flat surface to avoid deformations.
- If the equipment is stored without suitable packaging it is important to keep the valve's moving parts lubricated, for this reason it is recommended to carry out regular checks and lubrication.
- Likewise, if there are any machined surfaces without surface protection it is important for some form of protection to be applied to prevent the appearance of corrosion.

C.M.O.

Amategui Aldea 142, 20400 Txarama-Tolosa (SPAIN)

MAN-FK.EN02

Tel. National: 902.40.80.50 Fax: 902.40.80.51 / Tel. International: 34.943.67.33.99 Fax: 34.943.67.24.40

cmo@cmo.es <http://www.cmo.es>

Page 11



KNIFE GATE VALVES

SERIES FK

COMPONENTS LIST (manual valve)

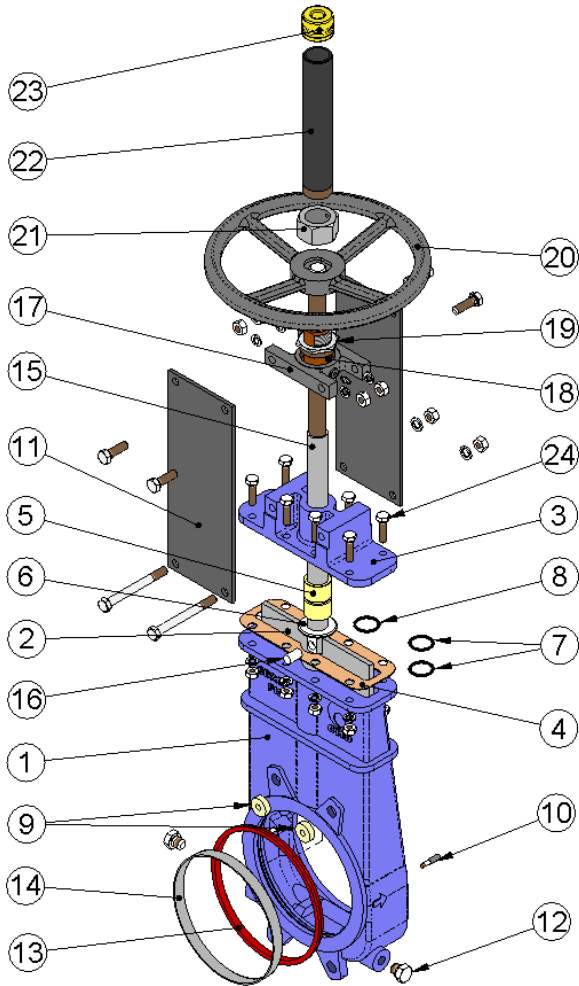

fig. 11

COMPONENTS LIST	
POS	DESCRIPTION
1	BODY
2	THROUGH CONDUIT
3	COVER
4	SEAT SEAL
5	BUSHING
6	STOP WASHER
7	INTERIOR O-RING SEAL
8	EXTERIOR O-RING SEAL
9	SEAT
10	THROUGH CONDUIT STOPPER
11	SUPPORT
12	THREADED CAP
13	SEAL
14	RING
15	STEM
16	CYLINDRICAL PIN
17	YOKE
18	STEM NUT
19	STOPPER NUT
20	HANDWHEEL
21	HOOD NUT
22	HOOD
23	PROTECTION CAP
24	SCREWS

table 7