



## DAMPER

## SC SERIES

25/02/2011

### SC DAMPER

The SC Model is a damper for assembly between flanges in gas tubes. SC dampers are composed of one single gate-blade and short opening and closing times. The CMO standard model is designed to work with pressures up to 600mbar, with recommended speeds of less than 35 m/s and temperatures up to 900°C.

It is a relative watertight valve with a closing degree of 98% to 99% in its metal/metal seal version, which can reach 99.9% if a joint sealing system is included.

The standard SC louver is designed to ensure it is assembled in such a way that the drive shaft always remains in a horizontal position, however, it can be fitted with vertical shafts on request.

#### STANDARD SC DAMPER

##### Description

The SC damper is composed of a blade which turns on a shaft located on one side (like a gate). The ends are joined to the pipes via flanges. Normally, the SC damper is supplied as one piece, except in those applications in which the dimensions of the equipment require special transport.

##### Construction

The body of the SC damper is machine welded and can be made of different materials. The standard construction sizes range from 150x150 mm (minimum) to 3000x3000 mm although larger sizes are available on request.

The blade is made flat, with reinforcing ribs and is supported on two semi-shafts. The flat blade system is sufficiently rigid for the working pressures of these valves and they do not produce significant load losses.

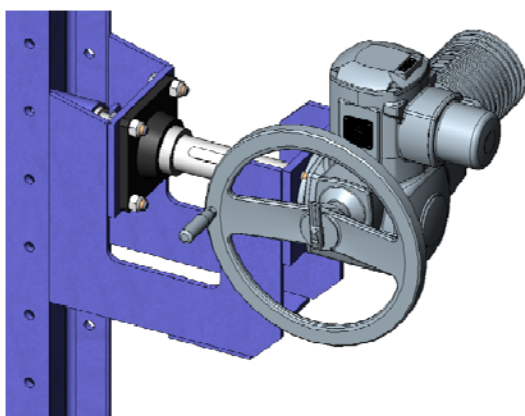
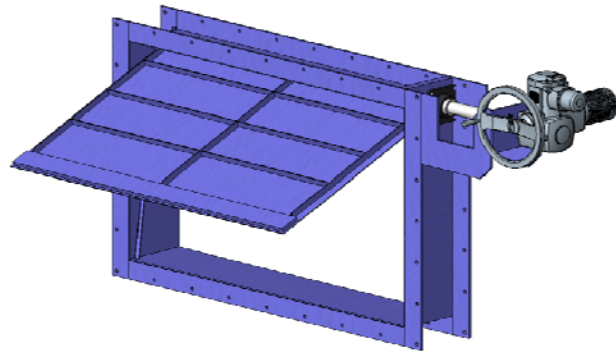

##### Sealing Systems

The SC dampers have two types of seals. Depending on the application you can choose between: Swing-thru (97% seal), for environments with high dust concentrations, the metal/metal seal (99% seal) and the step-seat joint for other applications that require greater watertight integrity, reaching 100% with air chamber sealing.

##### Bearings

CMO supplies its dampers with bearings fitted to the outside and separate from the packing. This ensures they are protected from heat sources and corrosion, extending their working life. This system also allows the packing to be changed without the need to remove the bearings, making future maintenance tasks easier.

##### Insulation

CMO supplies its valves ready for external insulation of 200 mm. In order to change the bearings and packing in the future without the need to remove the insulation, a space is left free for this purpose.